

# Battery Installation and Replacement

## ARRIS TM402G Model & TM402P Model

### Battery Replacement Action

1. Pull down on the two latches holding the battery door (on the bottom of the modem) and pull the door toward you. Set the door aside in a safe place.

Note: Model TM402G has only one Bay

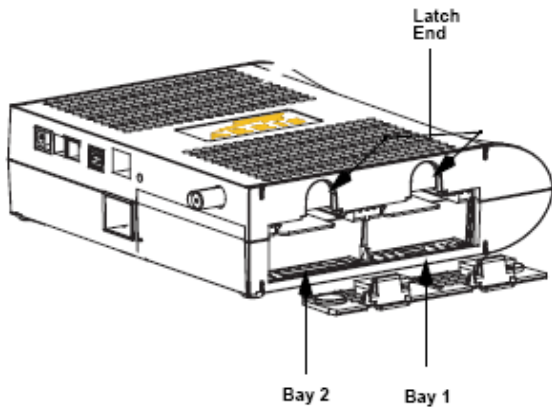

2. Hold each battery by its pull tab and insert the batteries into the bay. The photo below shows the proper orientation. Batteries will not insert completely into the modem if not oriented correctly. For Model TM402P insert the battery into Bay 1. Model TM402G has only one Bay.

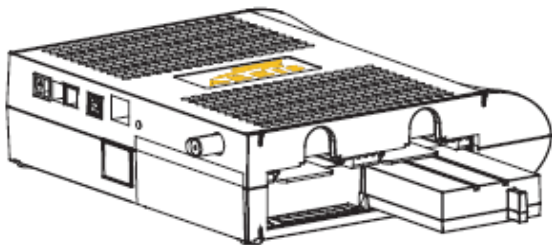

3. Push the battery into the bay until it latches into place. The following photo shows a modem with both batteries installed. Both Models only have one battery so Model TM402P should have the battery inserted in Bay 1 and Model TM402G will have the battery inserted into the available bay.

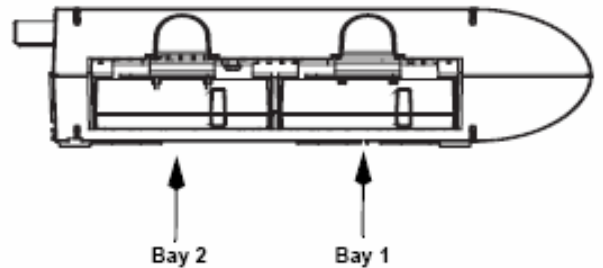

**Note:** The modem will not begin operating until you apply AC power.

4. Replace the door. To do so, place the tabs of the battery door into the slot on the modem battery compartment. Rotate the door away from you until the latch/latches snap back into place.

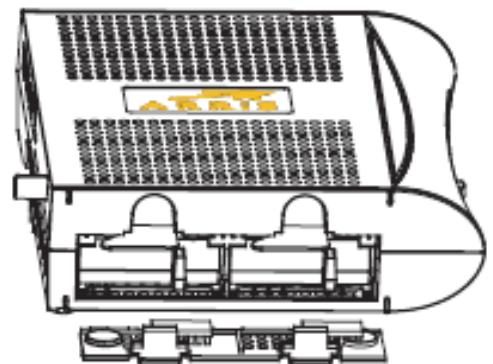

Unplug your CDV modem from the power outlet to install the battery. Once the battery installation is complete, plug your CDV modem back into the power outlet. Check for dialtone. The battery can take up to 24 hours to fully recharge, If you do not have dialtone, please call us at 800-948-5385 for assistance. Thank you!