



---

*User Guide*

---

RNG200N

High-Definition All-Digital Dual Tuner DVR  
Set-top



MOTOROLA and the Stylized M logo are trademarks or registered trademarks of Motorola Trademark Holdings, LLC. CableCARD, M-Card , and DOCSIS are trademarks or registered trademarks of Cable Television Laboratories, Inc. HDMI, the HDMI logo, and High-Definition Multimedia Interface are trademarks or registered trademarks of JDMI Licensing LLC. Dolby, Pro Logic, and the double-D symbol are registered trademarks of Dolby Laboratories. Macrovision is a registered trademark of Macrovision Corporation. MoCA and the MoCA logo are trademarks of Multimedia over Coax Alliance. All other product or service names are the property of their respective owners. All other product or service names are the property of their respective owners.

©2010 Motorola Mobility, Inc. All rights reserved.

No part of this publication may be reproduced in any form or by any means or used to make any derivative work (such as translation, transformation, or adaptation) without written permission from Motorola, Inc. Motorola reserves the right to revise this publication and to make changes in content from time to time without obligation on the part of Motorola to provide notification of such revision or change. Motorola provides this guide without warranty of any kind, implied or expressed, including, but not limited to, the implied warranties of merchantability and fitness for a particular purpose. Motorola may make improvements or changes in the product(s) described in this manual at any time.



# Safety & Regulatory Information

## IMPORTANT SAFETY INSTRUCTIONS

- Read these instructions.
- Keep these instructions.
- Heed all warnings.
- Follow all instructions.
- Do not use this apparatus near water.
- Clean only with dry cloth.
- Do not block any ventilation openings. Install in accordance with the manufacturer's instructions.
- Do not install near any heat sources such as radiators, heat registers, stoves, or other apparatus (including amplifiers) that produce heat.
- Do not defeat the safety purpose of the polarized or grounding type plug. A polarized plug has two blades with one wider than the other. A grounding type plug has two blades and a third grounding prong. The wide blade or the third prong is provided for your safety. If the provided plug does not fit into your outlet, consult an electrician for replacement of the obsolete outlet.
- Protect the power cord from being walked on or pinched particularly at plugs, convenience receptacles, and the point where they exit from the apparatus.
- Only use attachments/accessories specified by the manufacturer.
- Unplug this apparatus during lightning storms or when unused for long periods of time.
- Refer all servicing to qualified service personnel. Servicing is required when the apparatus has been damaged in any way, such as the power supply cord or plug is damaged, liquid has been spilled or objects have fallen into the apparatus, the apparatus has been exposed to rain or moisture, does not operate normally, or has been dropped.

## IMPORTANT SAFETY CONSIDERATIONS

The RNG3501 set-top requires careful handling to avoid potential damage to its internal hard disk drive or the loss of recorded data. Be sure to follow these requirements during transportation and installation.

The plug is the main disconnect device. It shall remain readily accessible and operable.

The apparatus shall not be exposed to dripping or splashing and no objects filled with liquids, such as vases, shall be placed on the apparatus.

### During Transportation to the Subscriber Home

Transport the cable terminal in its shipping box or an equally padded container.

Do not expose the terminal to rain or moisture.

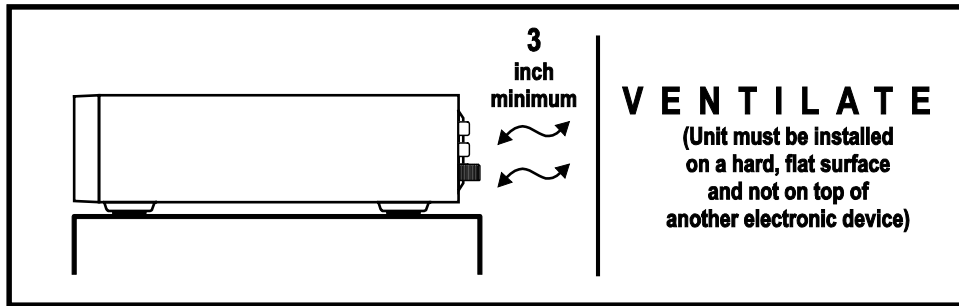

### During Installation

- Do not place the terminal in an enclosed area where the cooling vents are blocked or impede the flow of air through the ventilation openings.
- Install the terminal so that its position does not interfere with its proper ventilation. For example, do not place the terminal on a bed, sofa, rug, or similar surface that could block the ventilation openings.
- Install the terminal away from heat sources such as radiators, heat registers and stoves. Installation of the terminal near consumer electronics devices, such as stereo receiver/amplifiers and televisions, is permitted as long as the air surrounding the terminal does not exceed 40° C (104° F).
- Place the terminal on a flat surface not prone to vibration or impact.
- Do not install the terminal in an area where condensation occurs.
- To prevent the temporary loss of guide data and cause a temporarily non-responding terminal, do not plug the AC power cord into a switched power outlet.
- To avoid shock and vibration damage to the internal hard drive, do not move the terminal while it is plugged in.
- To allow the hard drive to spin down and park its heads, wait at least 10 seconds after disconnecting power before moving the terminal.

### FCC Compliance

Note: This equipment has been tested and found to comply with the limits for a Class B digital device, pursuant to part 15 of the FCC Rules. These limits are designed to provide reasonable protection against harmful interference in a residential installation. This equipment uses and can radiate radio frequency energy and, if not installed and used in accordance with the instructions, may cause harmful interference to radio communications. However, there is no guarantee that interference will not occur in a particular installation. If this equipment does cause harmful interference to radio or television reception, which can be determined by turning the equipment off and on, the user is encouraged to try to correct the interference by one or more of the following measures:

- Reorient or relocate the receiving antenna.
- Increase the separation between the equipment and set-top.
- Connect the equipment into an outlet on a circuit different from that to which the set-top is connected.
- Consult the dealer or an experienced radio/TV technician for help.

Caution: Changes or modifications not expressly approved by Motorola for compliance could void the user's authority to operate the equipment.

This device complies with part 15 of the FCC Rules. Operation is subject to the following two conditions: (1) This device may not cause harmful interference, and (2) this device must accept any interference received, including interference that may cause undesired operation.



## FCC Declaration Of Conformity

Motorola Mobility Inc., 101 Tournament Drive, Horsham, PA 19044, 1-215-323-1000, declares that the RNG200N set-top complies with 47 CFR Parts 2 and 15 of the FCC rules as a Class B digital device.

## Canada Industry Canada (IC)

This Class B digital device complies with Canadian ICES-003.

Cet appareil numérique de la classe B est conforme à la norme NMB-003 du Canada.

## Caring for the Environment by Recycling

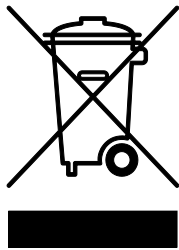

When you see this symbol on a Motorola product, do not dispose of the product with residential or commercial waste.

### Recycling your Motorola Equipment

Please do not dispose of this product with your residential or commercial waste. Some countries or regions, such as the European Union, have set up systems to collect and recycle electrical and electronic waste items. Contact your local authorities for information about practices established for your region. If collection systems are not available, call Motorola Customer Service for assistance.



# Software License

IMPORTANT: PLEASE READ THIS SOFTWARE LICENSE ("LICENSE") CAREFULLY BEFORE YOU USE ANY SOFTWARE, FIRMWARE AND RELATED DOCUMENTATION ("SOFTWARE") PROVIDED WITH MOTOROLA'S DIGITAL CABLE RECEIVER OR HOME THEATER SYSTEM (EACH SHALL BE REFERRED TO IN THIS LICENSE AS A "RECEIVER"). BY USING THE RECEIVER AND/OR USING ANY OF THE SOFTWARE, YOU INDICATE YOUR ACCEPTANCE OF EACH OF THE TERMS OF THIS LICENSE. UPON ACCEPTANCE, THIS LICENSE WILL BE A LEGALLY BINDING AGREEMENT BETWEEN YOU AND MOTOROLA. THE TERMS OF THIS LICENSE APPLY TO YOU AND TO ANY SUBSEQUENT USER OF THIS SOFTWARE.

IF YOU DO NOT AGREE TO ALL OF THE TERMS OF THIS LICENSE (I) DO NOT USE THE SOFTWARE AND (II) RETURN THE RECEIVER AND THE SOFTWARE (COLLECTIVELY, "PRODUCT"), INCLUDING ALL COMPONENTS, DOCUMENTATION AND ANY OTHER MATERIALS PROVIDED WITH THE PRODUCT, TO YOUR POINT OF PURCHASE OR SERVICE PROVIDER, AS THE CASE MAY BE, FOR A FULL REFUND.

The Software includes associated media, any printed materials, and any "on line" or electronic documentation. Software provided by third parties may be subject to separate end user license agreements from the manufacturers of such Software. The Software is never sold. Motorola licenses the Software to the original customer and to any subsequent licensee for personal use only on the terms of this License. Motorola and its third party licensors retain the ownership of the Software.

You may:

USE the Software only in connection with the operation of the Product.

TRANSFER the Software (including all component parts and printed materials) permanently to another person, but only if the person agrees to accept all of the terms of this License. If you transfer the Software, you must at the same time transfer the Product and all copies of the Software (if applicable) to the same person or destroy any copies not transferred.

TERMINATE this License by destroying the original and all copies of the Software (if applicable) in whatever form.

You may not:

(1) Loan, distribute, rent, lease, give, sublicense or otherwise transfer the Software, in whole or in part, to any other person, except as permitted under the TRANSFER paragraph above. (2) Copy or translate the User Guide included with the Software, other than for personal use. (3) Copy, alter, translate, decompile, disassemble or reverse engineer the Software, including but not limited to, modifying the Software to make it operate on non compatible hardware. (4) Remove, alter or cause not to be displayed, any copyright notices or startup message contained in the Software programs or documentation. (5) Export the Software or the Product components in violation of any United States export laws.

The Product is not designed or intended for use in on line control of aircraft, air traffic, aircraft navigation or aircraft communications; or in design, construction, operation or maintenance of any nuclear facility. MOTOROLA AND ITS THIRD PARTY LICENSORS DISCLAIM ANY EXPRESS OR IMPLIED WARRANTY OF FITNESS FOR SUCH USES. YOU REPRESENT AND WARRANT THAT YOU SHALL NOT USE THE PRODUCT FOR SUCH PURPOSES.

Title to this Software, including the ownership of all copyrights, mask work rights, patents, trademarks and all other intellectual property rights subsisting in the foregoing, and all adaptations to and modifications of the foregoing shall at all times remain with Motorola and its third party licensors. Motorola retains all rights not expressly licensed under this License. The Software, including any images, graphics, photographs, animation, video, audio, music and text



incorporated therein is owned by Motorola or its third party licensors and is protected by United States copyright laws and international treaty provisions. Except as otherwise expressly provided in this License, the copying, reproduction, distribution or preparation of derivative works of the Software, any portion of the Product or the documentation is strictly prohibited by such laws and treaty provisions. Nothing in this License constitutes a waiver of Motorola's rights under United States copyright law.

This License and your rights regarding any matter it addresses are governed by the laws of the Commonwealth of Pennsylvania, without reference to conflict of laws principles. THIS LICENSE SHALL TERMINATE AUTOMATICALLY if you fail to comply with the terms of this License.

Motorola is not responsible for any third party software that is provided as a bundled application, or otherwise, with the Software or that is downloaded to, or otherwise installed on, the Product.

#### U.S. GOVERNMENT RESTRICTED RIGHTS

The Product and documentation is provided with RESTRICTED RIGHTS. The use, duplication or disclosure by the Government is subject to restrictions as set forth in subdivision (c)(1)(ii) of The Rights in Technical Data and Computer Software clause at 52.227 7013. The contractor/manufacturer is Motorola Mobility, Inc., 101 Tournament Drive, Horsham, PA 19044.



# Contents

<b>Safety &amp; Regulatory Information</b> .....	<b>i</b>
<b>Software License</b> .....	<b>iv</b>
<b>Introduction</b> .....	<b>1</b>
Overview .....	1
Front Panel.....	2
Rear Panel.....	3
<b>Operation</b> .....	<b>4</b>
Turning Power On and Off .....	4
Changing Channels.....	4
Adjusting the Volume .....	4
Interactive Program Guide.....	4
Front Panel Format Button .....	5
Operation .....	5
Video Format Indicators (Front Panel Display) .....	5
M-Card™.....	6
<b>Digital Video Recorder (DVR)</b> .....	<b>7</b>
<b>Connecting Your RNG Set-top</b> .....	<b>9</b>
Video Connection Options.....	9
HDMI or IEEE-1394 — HDTV and SDTV.....	10
Component video (YPbPr) — HDTV and SDTV.....	10
S-Video — SDTV .....	10
Composite Video — SDTV.....	10
RF Output — SDTV.....	10
Connecting HDTV — Single Connection for Video/Audio.....	11
Connecting Your RNG Set-top to an HDTV — Single Connection for Video/Audio.....	12
Connecting HDTV — Separate Video/Audio Connections.....	13
Cable In .....	13
DVI.....	13
Component Video (YPbPr).....	13
Audio .....	13
Connecting Your RNG Set-top to an HDTV — Separate Video/Audio.....	14
Connecting Your RNG Set-top to an HDTV — Alternate Audio.....	15
Connecting an A/V Receiver — Audio.....	16
Connecting Your RNG Set-top to an A/V Receiver — Audio.....	17





---

Connecting an SDTV.....	18
Connecting Your RNG Set-top to an SDTV.....	18
Connecting an A/V Receiver, SDTV, and VCR/DVD Recorder.....	19
Connecting Your RNG Set-top to an A/V Receiver, SDTV, and VCR/DVD Recorder.....	20
Connecting Your Set-top to an External eSATA DVR.....	21
<b>Recording Your Connections.....</b>	<b>22</b>
Data Devices.....	23
Data Features.....	23
<b>On-Screen Graphics.....</b>	<b>24</b>
<b>Configuring A/V, Closed Captioning, and Other Settings.....</b>	<b>25</b>
User Settings Menu Main Screen.....	26
Native Mode Settings Screen.....	32
Additional HDMI Settings Screen.....	35
Additional Closed Caption Settings Screen.....	38
Subtitle and DVS Settings Screen.....	40
Advanced Audio/Video Settings Screen.....	42
<b>Troubleshooting.....</b>	<b>44</b>



# 1

## Introduction

### Overview

Congratulations on receiving a Motorola RNG200N Series High-Definition All-Digital Dual Tuner Cable Set-top, one of the most advanced interactive digital cable set-tops available today. Motorola has merged the extraordinary features of digital cable — the seemingly endless programming options, interactive program guides, Video on Demand (VOD), and commercial-free, CD quality music — with the flexibility of a dual tuner-digital video recorder (DVR) and the incredible picture quality and sound of High-Definition TV (HDTV). The RNG200N includes an “Entertainment Package” that enables a direct digital connection to consumer audio and video devices through IEEE-1394 and HDMI™ interfaces. Dolby® Digital Plus is supported by the HDMI interface and provides 7.1 channels and beyond of enhanced-quality audio. The set-top is fully equipped with a factory-installed hard drive for hours of DVR functionality, which includes the capability of recording two High-Definition programs, or watching one while recording another.

This User Guide introduces you to the basic features, outlines important safeguards, and provides several options for integrating this component into your current entertainment system. Please take a few moments to read through this User Guide; the configuration diagrams, on-screen menu description, and troubleshooting sections will help you make the most of your home entertainment experience.

To determine which features of digital cable are provided in your service area, please check with your local cable operator. They will be happy to provide instructions for these optional services.

#### Features

- All-Digital Dual Tuner High Definition DVR M-Card Host (dual tuners support watch and record mode)
- Dual Advanced A/V High-Definition decode
- Integrated MoCA™ networking
- HDMI, Component, IEEE-1394, S-Video, Composite, RF remod, Digital Audio (S/PDIF), Audio L/R, Ethernet, USB, eSATA
- 1080p 24/30 video decode and 1080p 24/30/60 video output support



## Front Panel



- |   |   |
|---|---|
| 1 | Cursor — Menu navigation<br>Select — Selects menu options |
| 2 | Power — Turns the set-top on and off (standby)            |
| 3 | Menu — Displays the menu                                  |
| 4 | Guide — Displays the program guide                        |
| 5 | Info — Displays current channel and program information   |
| 6 | Format * — Change the video output format                 |
| 7 | Channel — Changes channel up or down                      |

*\* Availability of certain features is dependent upon application support.*



## Rear Panel

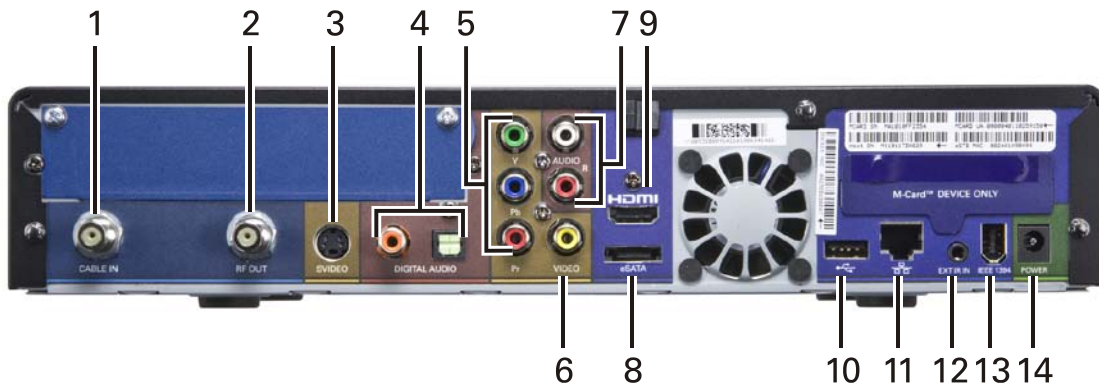

- |    |  |
|----|--|
| 1  | Cable In — Connects to cable signal from your service provider   |
| 2  | RF Out — Ch 3/4 modulated audio/video (SDTV) to TV or VCR  |
| 3  | S-Video — Connects to S-Video (SDTV) input of TV or VCR  |
| 4  | Digital Audio (Coaxial S/PDIF) — Provides Dolby® Digital or PCM output<br>Digital Audio (Optical S/PDIF) — Provides Dolby® Digital or PCM output |
| 5  | Video outputs / YPbPr — Component video output (HDTV)  |
| 6  | Video Out — Composite Video (SDTV)   |
| 7  | Audio Out — L/R audio  |
| 8  | eSATA* — External Serial ATA disk interface  |
| 9  | HDMI — High-Definition TV (HDTV) connector   |
| 10 | USB* 2.0 — High-Speed peripheral device connection   |
| 11 | Ethernet* — Network connection   |
| 12 | External IR Input — Connects to a remote control set-top accessory cable<br>Data test connector (service personnel only)                         |
| 13 | IEEE-1394 — Audio and video device connection  |
| 14 | Power connector  |

\* Availability of certain features is dependent upon application support.



# 2

## Operation

### Turning Power On and Off

Press power on the front panel or remote control to turn the RNG set-top on or off (standby). When using the remote control, be sure it is in cable mode by pressing cable before pressing power. When using the front panel please note that the front panel buttons are touch-sensitive, so simply touch the power icon to turn on the set-top.

### Changing Channels

You can change channels in three ways:

- Press channel + or – on the front panel of the RNG set-top or the remote control to step through the channel selection.
- Enter the number of the channel you wish to view using the number keys on the remote control.
- Select the channel in the Interactive Program Guide.

### Adjusting the Volume

Press volume + or – on the remote control to adjust the volume. When you adjust the volume, the volume scale is displayed on the screen. Press mute on the remote control to toggle the sound on and off.

For best audio quality when using the analog L/R (var.) volume controlled audio outputs, use the remote control to set the RNG set-top to approximately three quarters of the maximum volume level and then adjust the audio levels on external devices such as your TV or A/V receiver.

When using the analog L/R (fixed) audio outputs or any of the digital audio outputs (HDMI, IEEE-1394, optical or coaxial digital audio) adjust the audio levels on your external device such as your TV or A/V receiver. You may also be able to program your remote to control the volume of your TV or A/V receiver directly (refer to the remote control instruction manual).

### Interactive Program Guide

The Interactive Program Guide displays information about TV programs and enables you to access features such as Parental Control or Pay-Per-View. Interactive program guides can vary with each cable service provider. Refer to the Interactive Program Guide's instruction manual for detailed instructions.



## Front Panel Format Button

The Format button located on the front panel of the RNG200N set-top allows you to quickly change the video output format used by the Component Video (YPbPr) and HDMI outputs. The RNG200N set-top is capable of providing the following video formats on the YPbPr and HDMI video outputs:

- High Definition 1080i (1920 x 1080 pixels)
- High Definition 720p (1280 x 720 pixels)
- Enhanced Definition 480p (720 x 480 pixels)
- Standard Definition 480i (720 x 480 pixels)

The RNG200N set-top is also capable of passing through High-Definition 1080p 24/30/60 (1920 x 1080 pixels) source content over the HDMI video output.

The Format button is intended to allow you to select a video output format that is compatible with a connected display device. Some televisions may not support all four video formats listed above. The Format button provides an easy method for selecting an output format that is compatible with your television.

## Operation

The Format button is intended to complement the User Settings Menu (see Configuring the Audio, Video, and Closed Caption Settings). It is not intended to replace the User Settings Menu. The User Settings Menu is the preferred method of optimizing the RNG set-top to operate with your specific television.

If you cannot get a video display when the RNG set-top is connected to your television via component video or standard HDMI cables, use the Format button to select a video output format that results in a viewable picture on the display screen. Once a viewable picture is available, use the User Settings Menu to optimize the RNG200N set-top display settings for your specific television.

## Video Format Indicators (Front Panel Display)

The front panel display of the RNG200N set-top is equipped with indicators to the right hand side of the display that are used to indicate the currently-selected video output format on the component video (YPbPr) and HDMI outputs. As the Format button is depressed, the front panel format indicators will change to illuminate the currently selected video output format in use by the RNG set-top.

*Note: There are some scenarios where the RNG set-top does not change the video output format if the Format button is depressed. In these scenarios, the RNG200N set-top will flash the currently illuminated video format indicator on the front panel display. If this should occur, please use the User Settings Menu to make further changes to the video output settings of the RNG200N set-top.*

*Note: Availability of certain features is dependent upon application support.*



---

## M-Card™

The M-Card is required to view cable television programs, previously recorded programs on the DVR, or interactive on-demand programs. The M-Card should not be removed.



# 3

## Digital Video Recorder (DVR)

The RNG200N set-top is equipped with an internal hard drive for DVR (Digital Video Recorder) functionality, which provides the ability to record both Standard Definition TV (SDTV) and High Definition TV (HDTV) programs. Storage time varies based on the video format and specific channel.

The RNG200N set-top is also equipped with an eSATA interface on the rear panel. This interface allows the connection of an external hard disk drive to increase the DVR storage capacity of the RNG200N. *Note: your service provider must authorize your RNG200N for external DVR functionality.*

DVR offers the ability to control your viewing experience by pausing (time shifting) live TV and providing trick playback modes (pause, fast forward, slow forward, fast rewind, slow rewind). You may experience a slight delay when switching between time-shifted and live TV.

The RNG200N model also includes integrated MoCA™ networking which supports whole-home DVR capabilities. This feature extends the DVR experience to RNG150N or other compatible non-DVR set-tops with integrated MoCA, when enabled by application software. On your non-DVR set-top you can now view your DVR recordings, playback content, and set future recordings all from another room in your home.

With the RNG200N set-top, you can:

**Record Programming.** The total hours of recorded content will vary based on the storage capacity of your DVR, the storage capacity of your specific external drive (if authorized), and type of content (digital SD or HD and encoding method, MPEG-2 or MPEG-4) being recorded.

Drive Size	Estimated Recording Hours	
	Standard Definition	High-Definition
500 GB	350 to 700 (MPEG-4)	100 to 160 (MPEG-4)
	175 to 350 (MPEG-2)	50 to 60 (MPEG-2)

**Maintain a Personal Program Library.** Accessed by using the Interactive Program Guide (IPG).

**Control Live TV.** Pause, rewind, and fast-forward live TV.

**Simultaneously Watch Two Programs.** Watch two programs and easily switch between them using the swap key on your remote control. (Dependent upon program guide support and provided remote control.)

**Simultaneous Watch and Record.** Record one program in the background while viewing another live broadcast at the same time.





**Simultaneously Record Two Shows.** Record two programs from two different channels at the same time.

**Simultaneously Record Two Shows and Watch a Recorded Program.** Watch a program recorded on your DVR while recording up to two other programs at the same time. You can also easily switch from viewing the pre-recorded program and either of the programs you're recording.

**Play Recorded Programming On Networked Set-tops In Your Home.** Using integrated MoCA networking, RNG200N recorded entertainment can be accessed by other compatible non-DVR set-tops with integrated MoCA, when enabled by application software.



# 4

## Connecting Your RNG Set-top

Instructions and diagrams are included for the following connections:

- High-Definition Television (HDTV)
- A/V receiver — Audio
- Standard-Definition TV (SDTV)
- Standard-Definition TV (SDTV) and VCR/DVD Recorder
- A/V receiver, Standard-Definition TV (SDTV), and VCR/DVD Recorder

Before you move or change components on your entertainment system, review the following:

- For basic cable connections, use 75 ohm coaxial cables equipped with F type connectors.
- Disconnect power from your equipment before connecting or changing cable connections.

For information on connecting to an HDTV, see *Video Connection Options*.

---

**Caution**      *Do not place anything on top of your RNG set-top, especially other home entertainment components. Be sure to provide adequate ventilation to prevent overheating.*

---

### Video Connection Options

The RNG set-top offers several different video connection options. Component video, HDMI, and IEEE-1394 allow you to view both High-Definition and Standard-Definition TV programming. Composite video, S-Video, and RF coaxial connections allow you to view only Standard-Definition TV programming. HD programming will be down-converted to SD format for SD outputs.

To determine whether your TV features component video, HDMI, IEEE-1394, S-Video, or composite video, check the manual supplied with your TV.

Use the guidelines below to determine the best video connection for your home entertainment system.

*Note: Only (1) video connection to the TV is required. HD video can only be viewed with HDMI, IEEE-1394, or component video connections.*



## HDMI or IEEE-1394 — HDTV and SDTV

- HDMI and IEEE-1394 offer higher quality HD video than component video.
- If your TV has an HDMI input, this is for both audio and video. Connect a Standard HDMI cable to the TV and to the HDMI connector on your RNG set-top.
- HDMI and IEEE-1394 outputs provide video and audio, so no separate audio connections are required if you plan to use your TV's speakers as the primary audio source.
- On screen graphics will not be displayed when you are using the IEEE-1394 connection on the rear panel of the RNG set-top. Refer to Section 6 for more information.
- If your TV has a DVI input, connect a HDMI-to-DVI adapter or cable to the HDMI out connector on the RNG set-top and the DVI HDTV connector on your TV.

*Note: DVI does not provide audio. A separate audio connection must be made.*

## Component video (YPbPr) — HDTV and SDTV

The YPbPr connectors on your RNG set-top provide HDTV and SDTV component video.

*Note: Component video does not provide audio. A separate audio connection must be made.*

## S-Video — SDTV

If a component video input is not available on your TV, use the S-Video connection.

*Note: S-Video does not provide audio. A separate audio connection must be made.*

## Composite Video — SDTV

If an S-Video input is not available on your TV, use the composite video (video) connection.

*Note: Composite video does not provide audio. A separate audio connection must be made.*

## RF Output — SDTV

If no other input is available on your TV, the RF Output of the RNG200N set-top can be connected to the Antenna or Cable Input on your TV. The RF Output carries both video and audio. Set your TV to channel 3 or 4.



---

## Connecting HDTV — Single Connection for Video/Audio

### Cable In

Connect an RF coaxial cable to the cable wall outlet and the CABLE IN connector on the RNG set-top.

### HDMI

If your TV has an HDMI input, this is for both audio and video if you are using the TV speakers. Connect a Standard HDMI cable to the TV and to the HDMI connector on your RNG set-top.

### IEEE-1394

If your HDTV has an IEEE-1394 connector, you can use the IEEE-1394 for both your video and audio connection. Connect an IEEE-1394 cable to the IEEE-1394 connector on your HDTV and RNG set-top.

*Note: On-screen graphics will not be displayed when you are using the IEEE-1394 connection on the rear panel of the RNG set-top. Refer to Section 6 for more information.*

If you have an audio/video receiver and are not using your TV's speakers, go to Connecting Your RNG Set-top to an A/V Receiver – Audio.



## Connecting Your RNG Set-top to an HDTV — Single Connection for Video/Audio

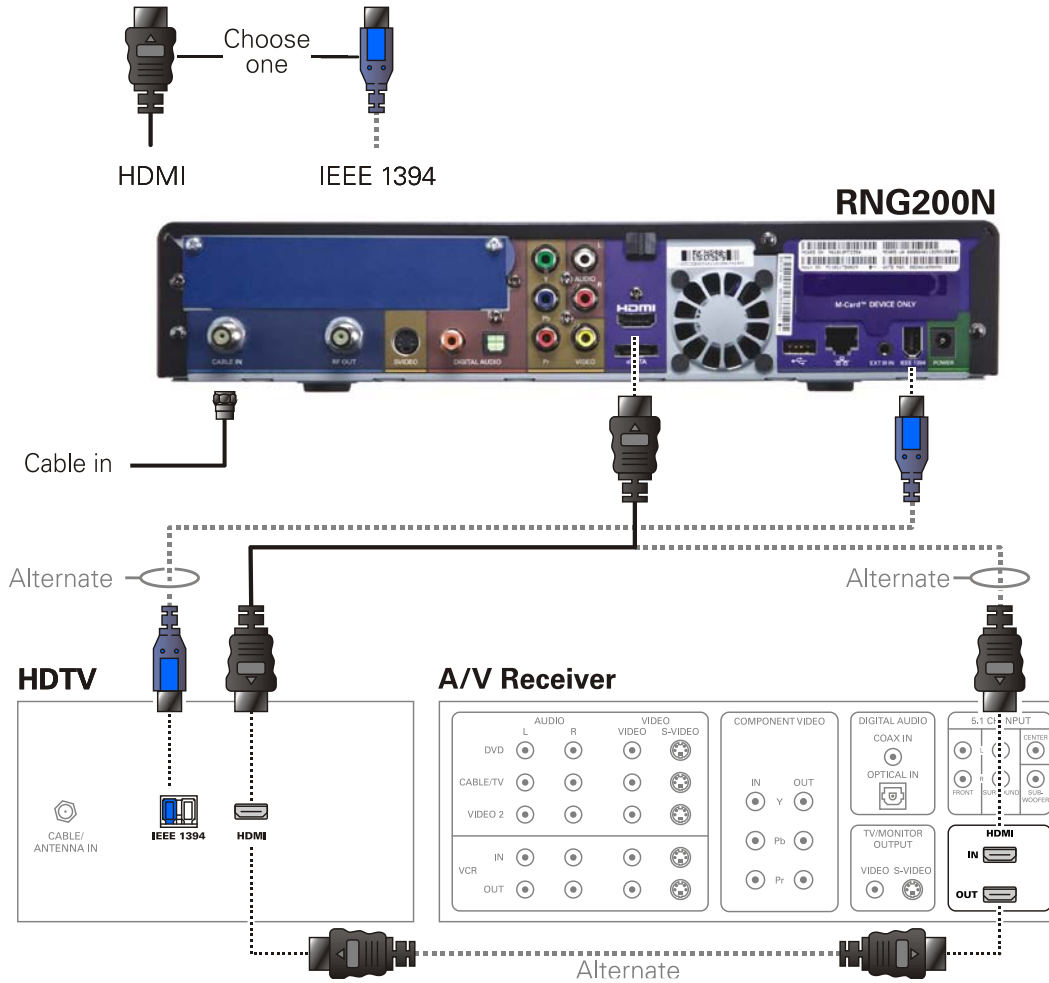

*Note: Only (1) HDTV video connection needs to be made to an HDTV.*

*Note: On-screen graphics will not be displayed when using IEEE-1394 connection. Refer to Section 6 for more information.*

*Note: Solid lines indicate optimum connections.*

*Note: Optional HDMI connection to A/V Receiver shown but not required.*



## Connecting HDTV — Separate Video/Audio Connections

### Cable In

Connect an RF coaxial cable to the cable wall outlet and the CABLE IN connector on the RNG set-top.

### DVI

If your TV has a DVI input, use the DVI connection for your video, connect a HDMI-to-DVI adapter or cable to the HDMI out connector on the RNG set-top and the DVI-HDTV connector on your TV.

*Note: A DVI connection supports only the video connection between the RNG set-top and the HDTV.*

*To connect your audio connections with your TV speakers, go to Audio section below.*

*To connect your audio connections for an A/V receiver, go to Connecting Your RNG Set-top to an A/V Receiver — Audio.*

### Component Video (YPbPr)

Connect the component video cables to the **Y**, **Pb**, and **Pr** connectors on your HDTV and RNG set-top.

*Note: This connection supports only the high definition video connection between the RNG set-top and the HDTV.*

*Note: Be sure to match up each signal to the same connection on the TV, otherwise the colors will not appear correctly on your TV.*

*To connect your audio connections with your TV speakers, go to Audio section below.*

*To connect your audio connections for an A/V receiver, go to Connecting Your RNG Set-top to an A/V Receiver — Audio.*

### Audio

If your TV does not have digital audio inputs, connect the stereo audio cable to the audio L/R connectors on the RNG200N set-top and the Audio L/R connectors on the HDTV.

If your TV supports a digital audio inputs, use the digital audio optical S/PDIF or coaxial S/PDIF outputs instead of the audio L/R outputs. S/PDIF offers better audio quality, including support for Dolby® Digital audio.

*For information on configuring your RNG set-top settings, go to Configuring the Audio, Video, and Closed Caption Settings.*



## Connecting Your RNG Set-top to an HDTV — Separate Video/Audio

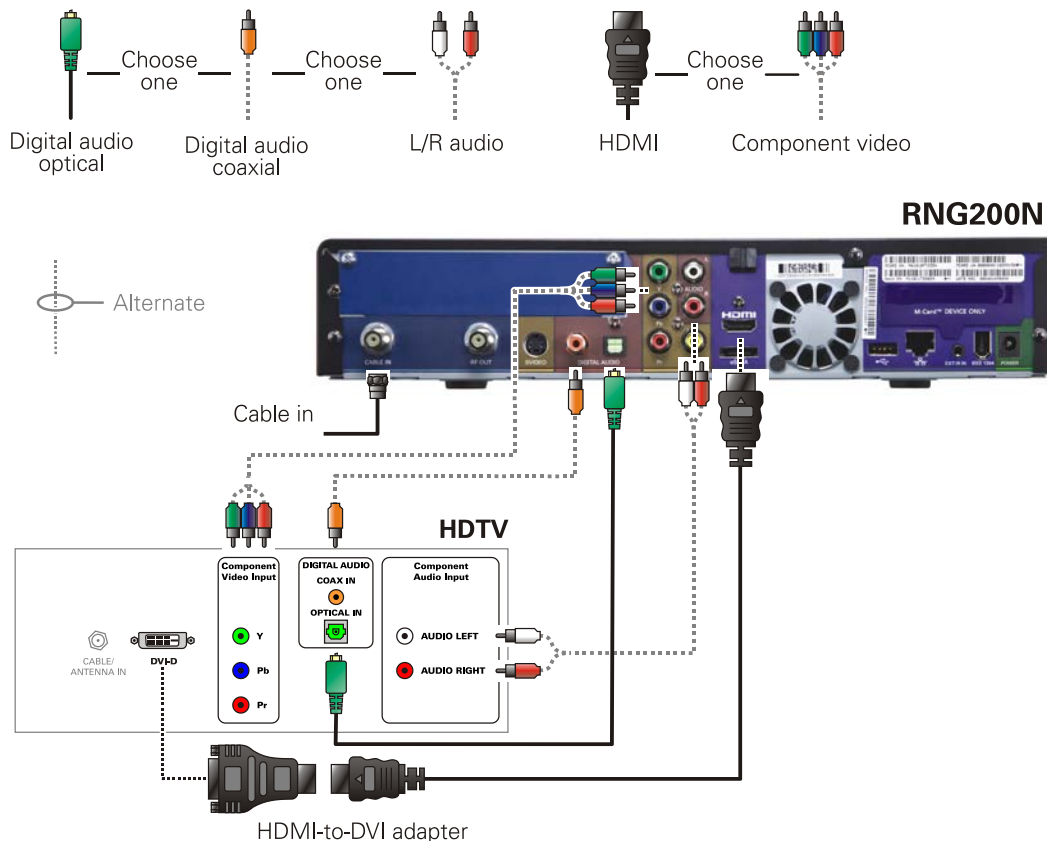

*Note: Only (1) video connection and (1) audio connection needs to be made to an HDTV.*

*Note: HDMI-to-DVI adapter is not included with the set-top.*

*Note: Solid lines indicate optimum connections.*



## Connecting Your RNG Set-top to an HDTV — Alternate Audio

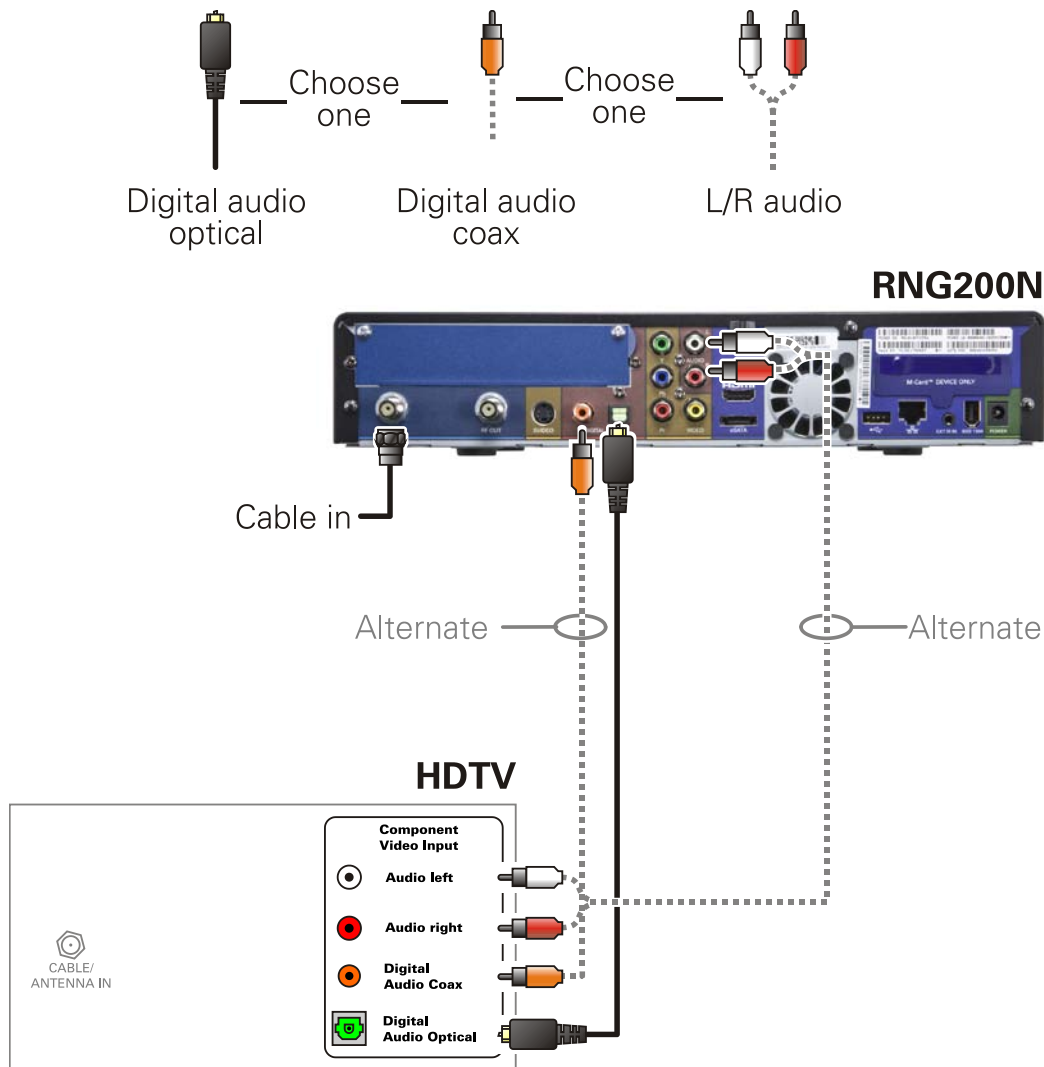

*Note: Only (1) audio connection needs to be made to an HDTV.*

*Note: Solid lines indicate optimum connections.*





---

## Connecting an A/V Receiver — Audio

There are several options available for audio connections to your A/V receiver:

- Digital audio (OPTICAL S/PDIF)
- Digital audio (COAXIAL S/PDIF)
- Stereo audio (AUDIO L/R)

If your A/V receiver supports it, the optical (S/PDIF) or coaxial (S/PDIF) digital audio outputs may be used in place of the stereo audio outputs (audio L/R). These outputs offer a higher level of audio quality, including support for Dolby Digital audio.

- **Digital audio optical (S/PDIF)**—Connect the optical cable to the digital audio OPTICAL connector on the RNG set-top and the optical connector on the A/V receiver.
- **Digital audio coaxial (S/PDIF)**—Connect the digital audio cable to the digital audio coaxial connector on the RNG set-top and the digital input coax connector on the A/V receiver.
- **Stereo audio**—Connect the stereo audio cable to the audio L/R connectors on the RNG set-top and the audio l/r connectors on the A/V receiver.

For information on configuring your RNG set-top settings, see *Configuring the Audio, Video, and Closed Caption Settings*.



## Connecting Your RNG Set-top to an A/V Receiver — Audio

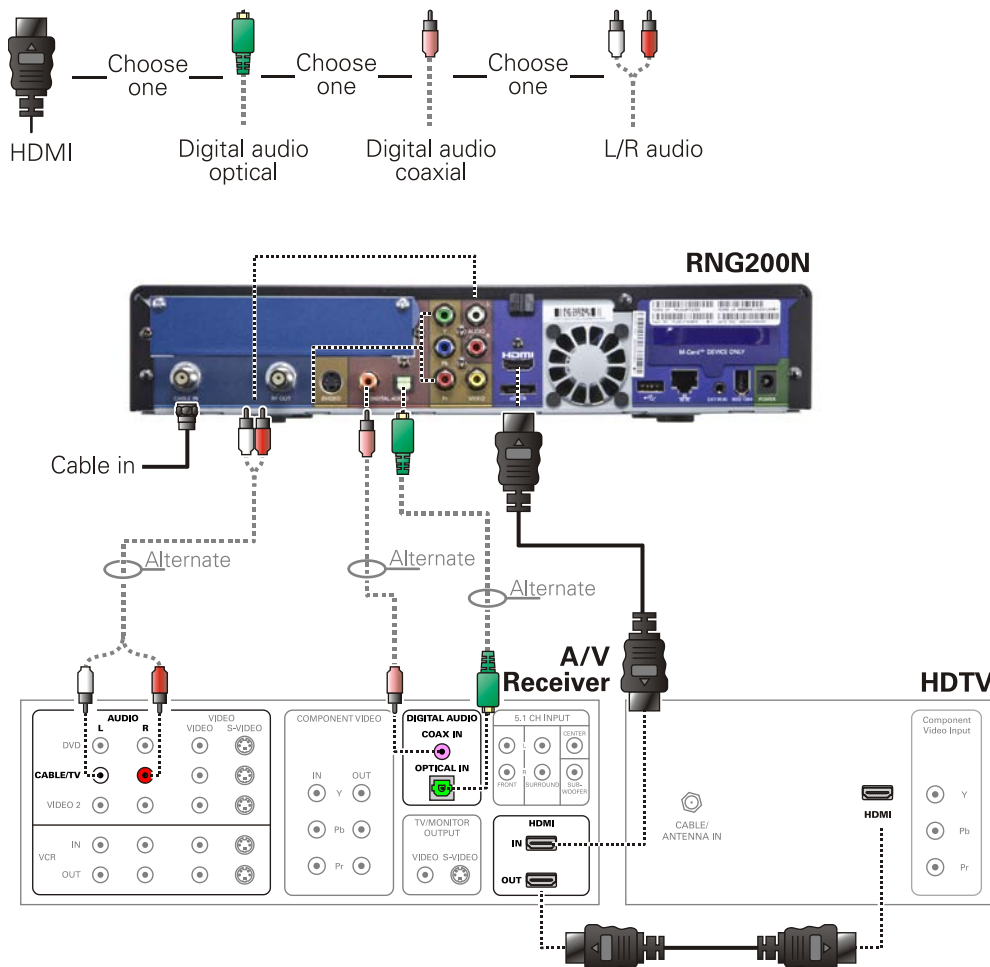

Note: Only (1) audio connection needs to be made to an A/V Receiver.

Note: Solid lines indicate optimum connections.



## Connecting an SDTV

1. Connect the stereo audio cable to the audio L/R connectors on the RNG set-top and the audio L/R connectors on the Standard-Definition TV (SDTV).
2. Connect an S-Video cable to the S-Video out connector on the RNG set-top and the input S-Video on the TV.

*Note: If the TV does not support S-Video connections, composite video connections may be used in place of S-Video connection.*

*Note: If the TV does not support S-Video or composite video connections, use the RF out connector on the RNG set-top. The RF connection carries video and audio.*

*These video connection methods do not support HD video. If you have an HDTV, see Connecting HDTV — Single Connection for Video/Audio.*

## Connecting Your RNG Set-top to an SDTV

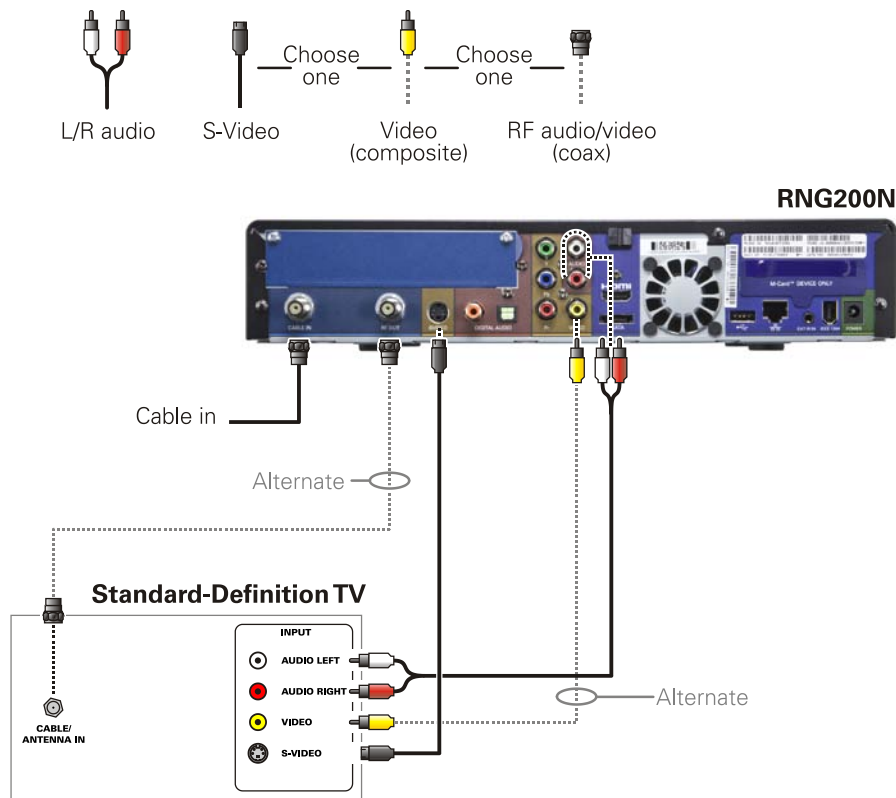

*Note: S-Video and Composite video require separate audio connections.*

*Note: Only (1) video connection and (1) audio connection is required.*

*Note: Solid lines indicate optimum connections.*



## Connecting an A/V Receiver, SDTV, and VCR/DVD Recorder

1. Connect a stereo audio cable to the AUDIO OUT L/R connectors on the RNG set-top and the input L/R connectors on the A/V receiver.
2. Connect an S-Video cable to the SVIDEO connector on the RNG set-top and the S-Video connector on the A/V receiver.
3. Note: If your A/V Receiver does not support S-Video connections, Composite video connections may be used in place of the S-Video connection.
4. Connect a stereo audio cable to the VCR audio out L/R connectors on the A/V receiver and the input audio L/R connectors on the stereo VCR.
5. Connect a stereo audio cable to the output audio out L/R connectors on the stereo VCR and the VCR audio in L/R connectors on the A/V receiver.
6. Connect a composite video cable to the input video connector on the stereo VCR and the video VCR out connector on the A/V receiver.
7. Connect a composite video cable to the output video connector on the stereo VCR and the video VCR in connector on the A/V receiver.
8. Connect an S-Video cable to the input S-Video connector on the Standard-Definition TV (SDTV) and the TV/monitor output S-Video connector on the A/V receiver.

*Note: If your TV or A/V receiver does not support S-Video connections, Composite connections may be used in place of the S-Video connections.*

*Note: The digital audio optical (optical S/PDIF) or digital audio (COAXIAL S/PDIF) audio outputs may be used in place of the stereo audio outputs (audio L/R). These outputs offer a higher level of audio quality, including support for Dolby Digital audio.*

*These video connection methods do not support HD video. If you have an HDTV, see Connecting HDTV — Single Connection for Video/Audio.*



## Connecting Your RNG Set-top to an A/V Receiver, SDTV, and VCR/DVD Recorder

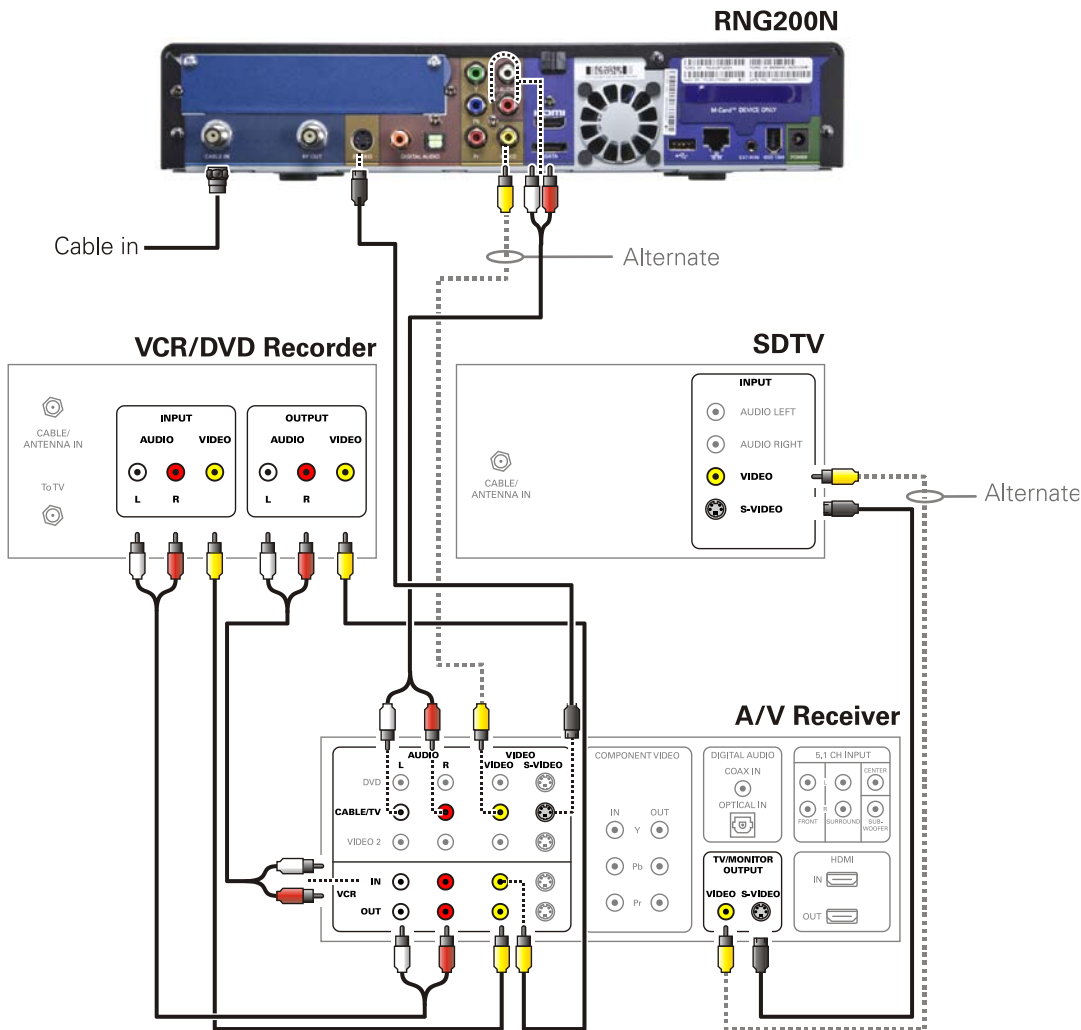
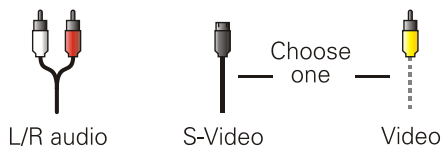

*Note: Solid lines indicate optimum connections.*

*Note: Consult your A/V receiver manual for additional wiring options or constraints when including a VCR/DVD Recorder in your configuration.*



## Connecting Your Set-top to an External eSATA DVR

1. Contact your cable service provider to verify the set-top software necessary to support External DVR Storage is available in your area.
2. Connect the AC power cord to the external drive and plug the external drive's AC power adapter into an electrical outlet.
3. Allow approximately 15 to 30 seconds for the external drive to reach operating speed.
4. Connect one end of the eSATA cable to the set-top.
5. Connect the other end of the eSATA cable to the external drive.
6. Follow the on-screen instructions.

*Note: Only connect external hard drives that have been approved by Motorola for external DVR service. Connecting an external drive that has not been approved could result in poor DVR performance.*

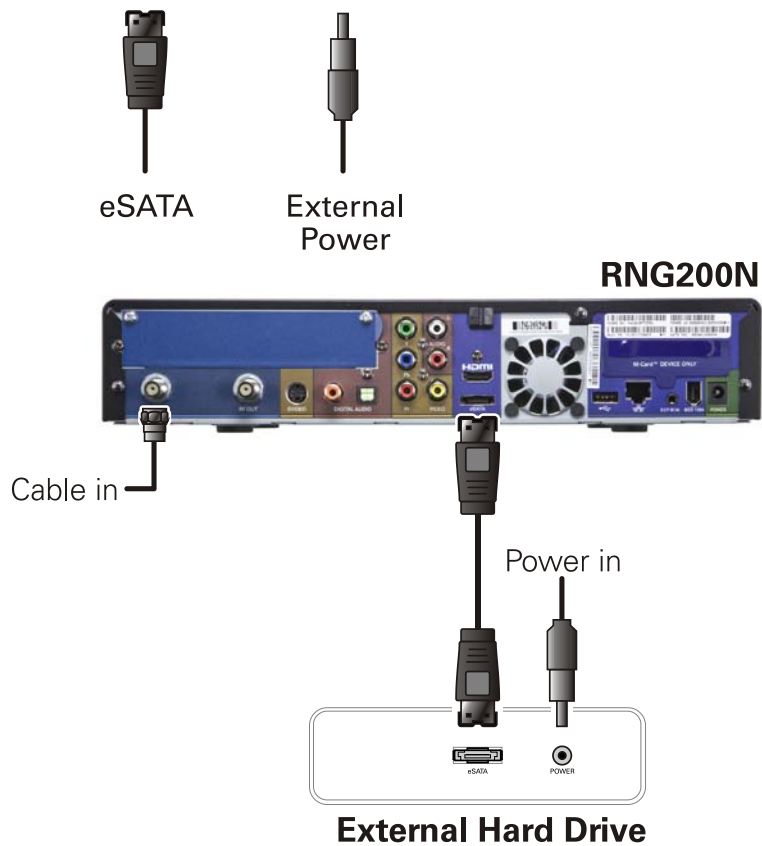



# 5

## Recording Your Connections

Use this diagram to record connections between your home entertainment components. You can use this diagram to reconnect your system if you move the equipment or add new equipment.

Disconnect the power from the RNG set-top before connecting or changing cable connections. Do not place another component or object on top of the RNG set-top.

**RNG200N**



**VCR / DVD Recorder**

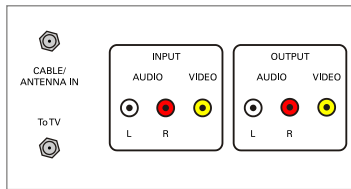

**HDTV / Standard-Definition TV**

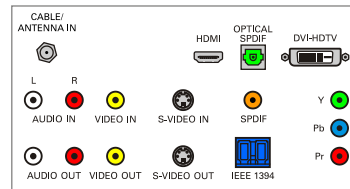

**Audio receiver**

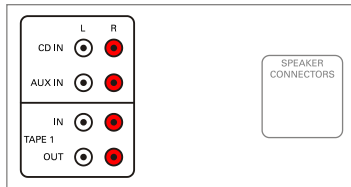

**DVD player**

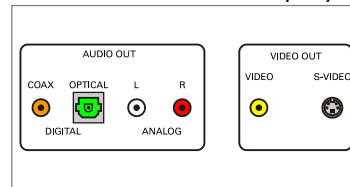

**A/V receiver**

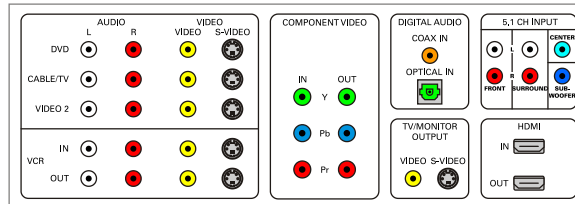



## Data Devices

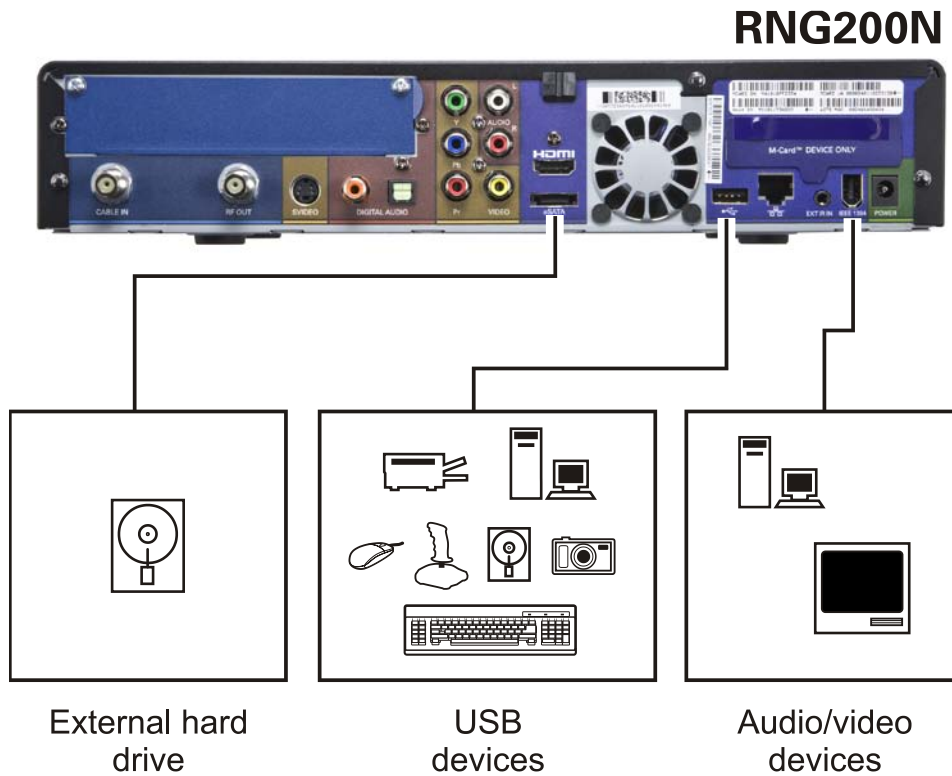

Do not attempt to connect data devices without contacting your service provider. Advanced data features require the proper application and network infrastructure to operate.

## Data Features

In addition to high-quality audio and video, the RNG set-top has the capability to deliver high-speed data services such as Internet access, e-mail, IP telephony, e-commerce, and home banking.

*Note: Your RNG set-top may be equipped with the interface connections illustrated, but their functionality depends on the services offered by your service provider.*





# 6

## On-Screen Graphics

Your RNG set-top can generate graphics that overlay the video programming or fill the entire television screen. Common examples include on-screen menus (such as the User Setting menu), closed captions, and interactive program guides. The RNG set-top overlays these graphics whenever you open a menu, enable closed captions, or scroll through a program grid.

- On-screen graphics are not available on all video output combinations.
- On-screen graphics will not be displayed when you are using the IEEE-1394 connection on the rear panel of the RNG set-top.



# 7

## Configuring A/V, Closed Captioning, and Other Settings

The following describes how to configure the audio (for HDMI connections), SD and HD video, closed caption, subtitle, and power settings for the RNG200N.

Before you adjust the output settings:

- Connect the RNG200N to the TV and other home entertainment devices
- Connect the provided power supply to the RNG200N and an AC power outlet
- Initialize the RNG200N and authorize it for services
- Turn the TV on

*Note: When using an HDMI connection between the RNG200N and the television, be sure to have the cable connected and the TV powered on before adjusting the video settings.*



## User Settings Menu Main Screen

To configure the RNG200N settings on the main User Settings menu screen, first power off the RNG200N using either the remote control or the Power button and then press the MENU key on the remote control . If the TV is on, the on-screen User Settings menu lists the RNG200N settings that can be adjusted.

If no HDMI device is connected to the RNG200N, the default User Settings menu appears as follows:

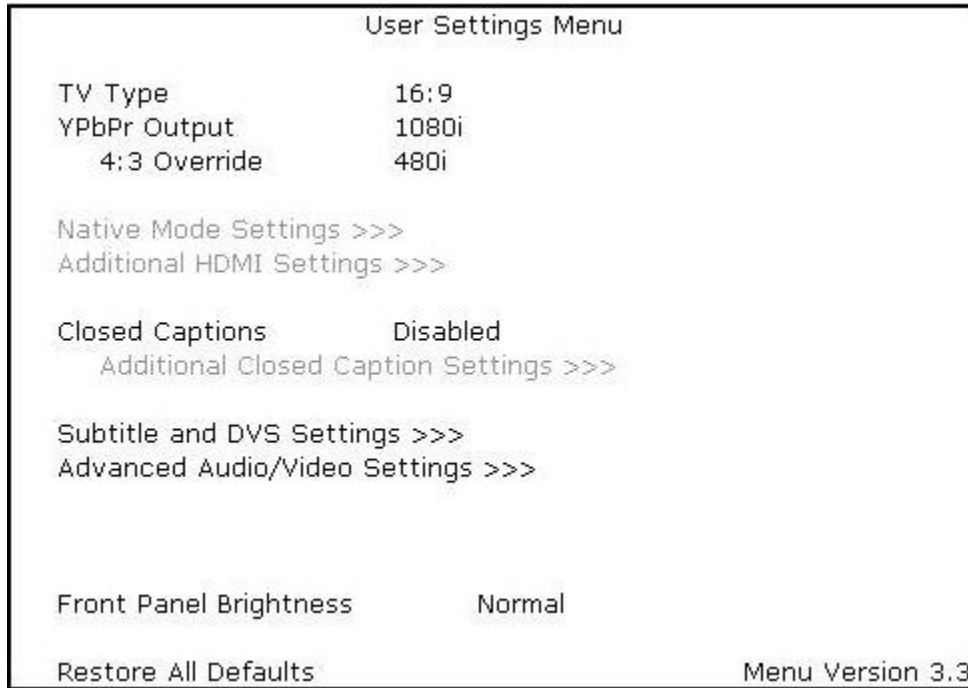

**Default User Settings Menu when no HDMI connection is in place**



If the RNG200N is connected via HDMI to a display device such as a television, the default User Settings menu is updated to reflect this information. The YPbPr Output menu option is replaced with the HDMI/YPbPr Output menu option as shown below.

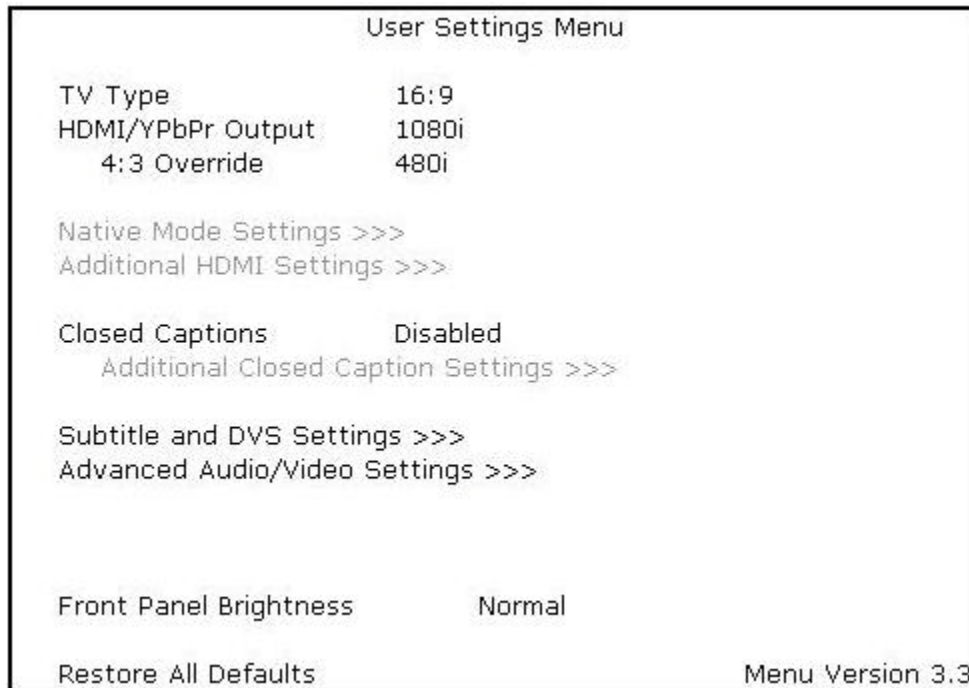

#### **Default User Settings Menu when an HDMI connection is in place**

Use the remote control cursor keys to navigate the on-screen menus as follows:

- Press the ▲ and ▼ keys to highlight the setting you wish to change.
- Press the ► key to select an option.
- To exit the setting and move to another setting, press the ▲ or ▼ key.



The User Settings menu options available from the main screen are illustrated and defined below.

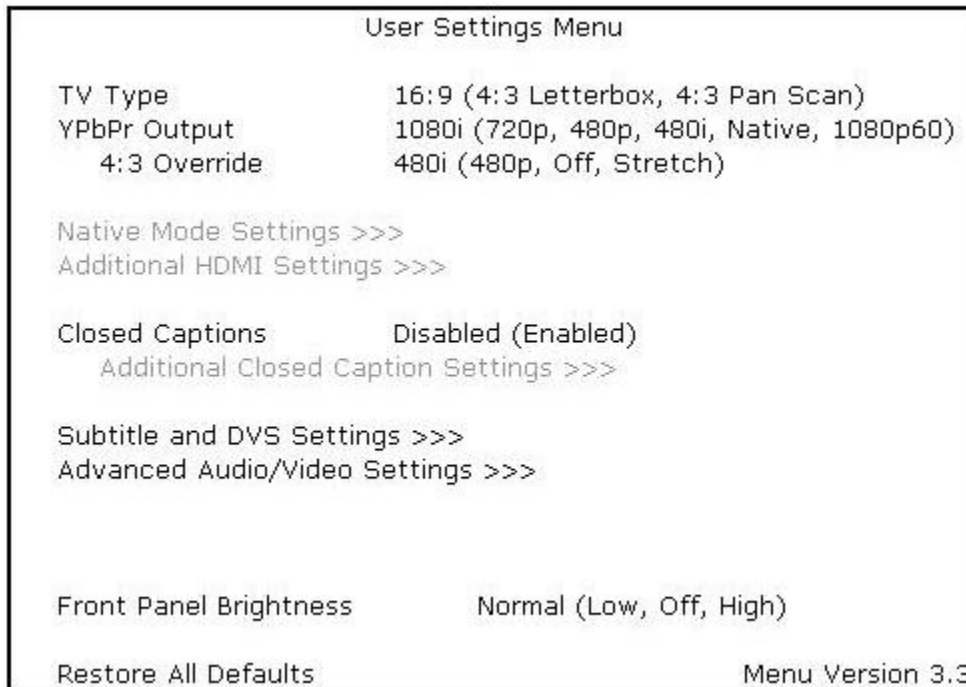

#### User Settings Menu – Main Menu Screen

Setting	Description
TV Type	<p>The <b>TV Type</b> setting allows you to specify the style of television connected to the RNG200N. Options include <b>16:9</b>, <b>4:3 Letterbox</b>, and <b>4:3 Pan Scan</b>. By default, the 16:9 option is selected. The options are used as follows:</p> <ul style="list-style-type: none"> <li>• <b>16:9</b> indicates that a widescreen television is connected to the RNG200N.</li> <li>• <b>4:3 Letterbox</b> indicates that a standard-screen television is connected to the RNG200N and that widescreen programs should be scaled to fit the screen with black bars above and below the picture.</li> <li>• <b>4:3 Pan Scan</b> indicates that a standard-screen television is connected to the RNG200N and that widescreen programs should be cropped so that the picture fills the entire screen.</li> </ul>
HDMI/YPbPr Output	<p>The <b>HDMI/YPbPr Output</b> setting allows you to select the video format of the HDMI and/or Component Video (YPbPr) outputs:</p> <ul style="list-style-type: none"> <li>• For ALL programs when the <b>4:3 Override</b> setting is set to either <b>Off</b> or <b>Stretch</b>.</li> <li>• For ONLY widescreen programs when the <b>4:3 Override</b> is set to either <b>480i</b> or <b>480p</b>.</li> </ul> <p>Available options for the <b>HDMI/YPbPr Output</b> setting include <b>1080i</b>, <b>720p</b>, <b>480p</b>, <b>480i</b>, and <b>Native</b>. By default, the 1080i option is selected.</p> <p>The options are used as follows:</p> <ul style="list-style-type: none"> <li>• <b>1080p60</b>—The RNG200N will present programs in the High-Definition 1080p60</li> </ul>



Setting	Description
	<p>format (1920 x 1080 pixels with progressive scanning at 60 frames per second).</p> <ul style="list-style-type: none"> <li>• <b>1080i</b>—The RNG200N will present programs in the High-Definition 1080i format (1920 x 1080 pixels with interlaced scanning at 30 frames per second).</li> <li>• <b>720p</b>—The RNG200N will present programs in the High-Definition 720p format (1280 x 720 pixels with progressive scanning at 60 frames per second).</li> <li>• <b>480p</b>—The RNG200N will present programs in the Enhanced-Definition 480p format (720 x 480 pixels with progressive scanning at 60 frames per second).</li> <li>• <b>480i</b>—The RNG200N will present programs in the Standard-Definition 480i format (720 x 480 pixels with interlaced scanning at 30 frames per second).</li> <li>• <b>Native</b>—The RNG200N will present programs in the format that most closely matches their native format according to the list of compatible formats selected from the Native Mode Settings menu screen.</li> </ul> <p><i>Note 1: Not all televisions will support all of the available video formats. Please consult the television's user manual for more information on video format compatibility.</i></p> <p><i>Note 2: The RNG200N can detect when the HDMI connection is in use. If you are not using the HDMI connection on the RNG200N, the <b>HDMI/YPbPr Output</b> setting will display as <b>YPbPr Output</b> in the User Settings Menu.</i></p> <p><i>Note 3: Most new HDTVs are equipped with at least one HDMI input and can support the 1080p60 format. The RNG200N is designed to provide excellent video quality when converting any program to the 1080p60 video format. If your television supports 1080p60 video input, it is highly recommended to adjust the <b>HDMI/YPbPr Output</b> setting to the <b>1080p60</b> setting.</i></p>



Setting	Description
4:3 Override	<p>The <b>4:3 Override</b> setting allows you to select the video output format of the RNG200N when it is tuned to a Standard-Definition program or playing back a Standard- Definition program from the DVR. Options include <b>480i</b>, <b>480p</b>, <b>Stretch</b>, and <b>Off</b>. By default, the 480i option is selected.</p> <p>The options are used as follows:</p> <ul style="list-style-type: none"> <li>• <b>480i</b>—The RNG200N will present Standard-Definition programs in the Standard-Definition 480i format (720 x 480 pixels).</li> <li>• <b>480p</b>—The RNG200N will present Standard-Definition programs in the Enhanced-Definition 480p format (720 x 480 pixels).</li> <li>• <b>Stretch</b>—The RNG200N will automatically stretch all Standard-Definition programs to a widescreen (16:9) aspect ratio and present the video in the format designated by the <b>HDMI/YPbPr Output</b> setting. Note that the <b>Stretch</b> option is only available when the <b>TV Type</b> setting is <b>16:9</b>.</li> <li>• <b>Off</b>—The RNG200N will create a widescreen version of a Standard-Definition program by adding black bars to the left and the right of the picture (pillarbox) and present the video in the format designated by the <b>HDMI/YPbPr Output</b> setting.</li> </ul> <p><i>Note 1: Not all televisions will support all of the available video formats. Please consult your television's user manual for more information on format compatibility.</i></p> <p><i>Note 2: If the <b>HDMI/YPbPr Output</b> setting is set to either <b>480i</b> or <b>Native</b>, the <b>4:3 Override</b> feature is disabled and no longer selectable in the menu. The <b>4:3 Override</b> feature is available when the <b>HDMI/YPbPr Output</b> setting is <b>1080i</b>, <b>720p</b>, or <b>480p</b>.</i></p>
Native Mode Settings	<p>The <b>Native Mode Settings</b> option allows you to customize the Native Mode feature of the RNG200N by selecting the video formats supported by your television. Selecting the <b>Native Mode Settings</b> option will present a new menu screen with settings specific to Native Mode operation. These settings are discussed in more detail below.</p> <p>The <b>Native Mode Settings</b> option is only available when the <b>HDMI/YPbPr Output</b> setting is set to <b>Native</b>. Otherwise, the <b>Native Mode Settings</b> option is disabled and no longer selectable in the menu.</p>
Additional HDMI Settings	<p>The <b>Additional HDMI Settings</b> option is available whenever an HDMI device is connected to the RNG200N. Selecting the <b>Additional HDMI Settings</b> option will present a new menu screen with settings specific to the HDMI connection. These settings are discussed in more detail below.</p> <p>If no HDMI device is connected to the RNG200N, the <b>Additional HDMI Settings</b> option is disabled and no longer selectable in the menu.</p>
Closed Captions	<p>The <b>Closed Captions</b> setting turns closed captions off or on.</p> <p>When this option is set to <b>Disabled</b>, the RNG200N does not render (draw) closed captions on any video output. When this option is set to <b>Enabled</b>, the RNG200N will render (draw) closed captions on all video outputs if closed captions are included within the program.</p> <p>By default, the <b>Disabled</b> option is selected.</p>



Setting	Description
Additional Closed Caption Settings	<p>The <b>Additional Closed Caption Settings</b> option allows you to customize the style and appearance of closed captions.</p> <p>Selecting this option will present a new menu screen with settings specific to closed captions, including font style, color, and size. These settings are discussed in more detail below.</p> <p>The <b>Additional Closed Caption Settings</b> option is only available when the <b>Closed Captions</b> setting is set to <b>Enabled</b>. Otherwise, the <b>Additional Closed Caption Settings</b> option is disabled and no longer selectable in the menu.</p>
Subtitle and DVS Settings	<p>The <b>Subtitle and DVS Settings</b> option allows you to customize the operation of the subtitle and descriptive video service features.</p> <p>Selecting the <b>Subtitle and DVS Settings</b> option will present a new menu screen with settings specific to subtitle and descriptive video service operation. These settings are discussed in more detail below.</p>
Advanced Audio/Video Settings	<p>The <b>Advanced Audio/Video Settings</b> option allows you to customize several advanced audio and video features of the RNG200N.</p> <p>Selecting this option will present a new menu screen with settings specific to closed captions, including font style, color, and size. These settings are discussed in more detail below.</p>
Front Panel Brightness	<p>The <b>Front Panel Brightness</b> settings allows you to adjust the brightness level of the front panel display (clock/channel number and indicator icons) of the RNG200N. The options are used as follows:</p> <ul style="list-style-type: none"> <li>• <b>High</b>—The front panel display will be at its brightest level. This setting is most useful when using the RNG200N in very brightly lit rooms</li> <li>• <b>Normal</b>—The front panel display will be at its default brightness level.</li> <li>• <b>Low</b> – The front panel display will be at its lowest (visible) brightness level. This setting is most useful when using the RNG200N in dim or dark rooms.</li> <li>• <b>Off</b>—The front panel display will be turned off completely, including the clock/channel number and all indicator icons. However, the blue backlighting of the front panel Power button will remain illuminated even if the Off option has been selected.</li> </ul>
Restore All Defaults	<p>To reset ALL of the RNG200N User Settings to their default values, including options stored on other menu screens, move the cursor to this option and press the ► key.</p>





## Native Mode Settings Screen

The Native Mode Settings menu is used to configure the operation of the native mode feature on the RNG200N. The RNG200N is capable of receiving and decoding a number of different digital video formats. When operating in native mode, the RNG200N will generate a video output format that most closely matches the broadcast video format .

For example, if the RNG200N is configured to operate in native mode, a channel broadcast in the 720p format will be output to the television in the 720p format, while a channel broadcast in the 1080i format will be output to the television in the 1080i format.

When using the native mode feature of the RNG200N, please exercise caution when selecting the formats from the checklist. If a format is selected that is not compatible with the television, there may be a loss of video whenever the RNG200N is tuned to a channel which is broadcast in that format.

If the television is connected to the RNG200N using an HDMI cable, the RNG200N will automatically customize the checklist of supported formats as reported to it by the television. If the television is connected to the RNG200N using Component Video (YPbPr) cables, the checklist will need to be customized manually. *Note that at least one of the [1080p - 1080i - 720p - 480p - 480i] formats must be selected from the checklist for the RNG200N to operate properly in native mode.*

The Native Mode Settings menu screen is illustrated and defined below.

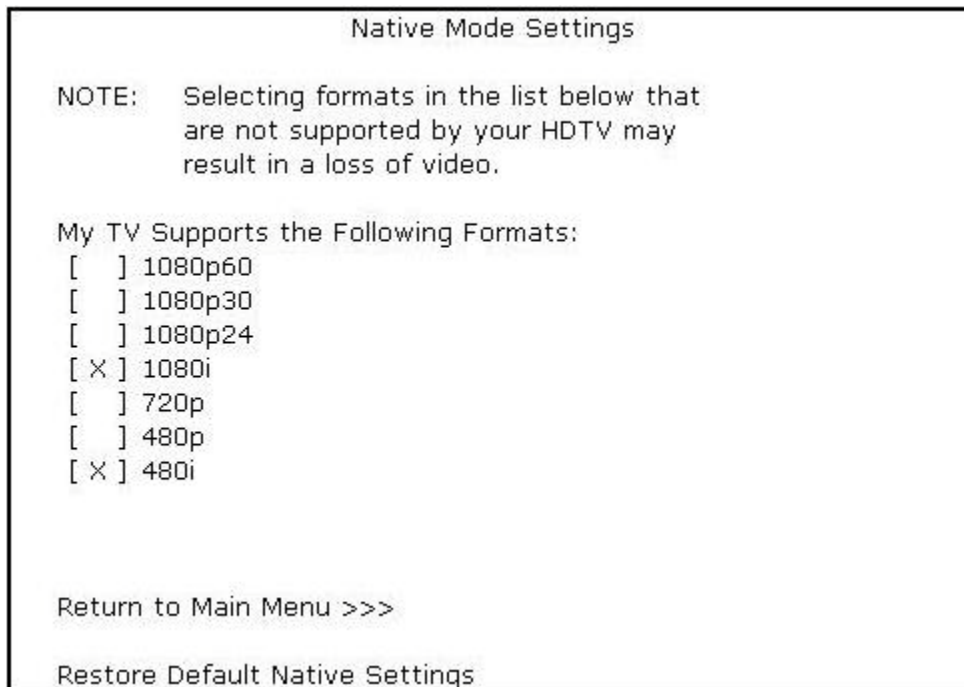

**Native Mode Settings menu screen**



Setting	Description
1080p60 (High Definition)	<p>If this option is selected, the RNG200N will generate 1080p60 video on the HDMI output if the program is broadcast in 1080p60 format. The RNG200N can also convert any other broadcast format to the 1080p60 video format.</p> <p>1080p60 is a high-definition video image with 1920 x 1080 pixels, progressive scanning, and a frame rate of 60 frames per second.</p> <p>This option is only available if the RNG200N is connected to an HDMI display device. If no HDMI connection is detected, this option is disabled and no longer selectable in the menu.</p> <p><i>Note: The Component Video (YPbPr) output delivers 480i video whenever the HDMI output is delivering 1080p60 video.</i></p>
1080p30 (High Definition)	<p>If this option is selected, the RNG200N will generate 1080p30 video on the HDMI output if the program is broadcast in 1080p30 format. The RNG200N cannot convert any other broadcast format to the 1080p30 video format.</p> <p>1080p30 is a high-definition video image with 1920 x 1080 pixels, progressive scanning, and a frame rate of 30 frames per second.</p> <p>This option is only available if the RNG200N is connected to an HDMI display device. If no HDMI connection is detected, this option is disabled and no longer selectable in the menu.</p> <p><i>Note: The Component Video (YPbPr) output delivers 480i video whenever the HDMI output is delivering 1080p30 video.</i></p>
1080p24 (High Definition)	<p>If this option is selected, the RNG200N will generate 1080p24 video on the HDMI output if the program is broadcast in 1080p24 format. The RNG200N cannot convert any other broadcast format to the 1080p24 video format.</p> <p>1080p24 is a high-definition video image with 1920 x 1080 pixels, progressive scanning, and a frame rate of 24 frames per second.</p> <p>This option is only available if the RNG200N is connected to an HDMI display device. If no HDMI connection is detected, this option is disabled and no longer selectable in the menu.</p> <p><i>Note: The Component Video (YPbPr) output delivers 480i video whenever the HDMI output is delivering 1080p24 video.</i></p>
1080i (High Definition)	<p>If this option is selected, the RNG200N will generate 1080i video on both the HDMI and Component Video (YPbPr) outputs if the program is broadcast in 1080i format. The RNG200N can also convert any other broadcast format to the 1080i video format.</p> <p>1080i is a high definition video image with 1920 x 1080 pixels, interlaced scanning, and a frame rate of 30 frames per second.</p>
720p (High Definition)	<p>If this option is selected, the RNG200N will generate 720p video on both the HDMI and Component Video (YPbPr) outputs if the program is broadcast in 720p format. The RNG200N can also convert any other broadcast format to the 720p video format.</p> <p>720p is a high-definition video image with 1280 x 720 pixels, progressive scanning, and a frame rate of 60 frames per second.</p>
480p (Enhanced Definition)	<p>If this option is selected, the RNG200N will generate 480p video on both the HDMI and Component Video (YPbPr) outputs if the program is broadcast in 480p format. The RNG200N can also convert any other broadcast format to the 480p video format.</p>



Setting	Description
	480p is an enhanced-definition video image with 720 x 480 pixels, progressive scanning, and a frame rate of 60 frames per second.
480i (Standard Definition)	<p>If this option is selected, the RNG200N will generate 480i video on both the HDMI and Component Video (YPbPr) outputs if the program is broadcast in 480i format. The RNG200N can also convert any other broadcast format to the 480i video format.</p> <p>480i is a standard-definition video image with 720 x 480 pixels, interlaced scanning, and a frame rate of 30 frames per second.</p>
Restore Default Native Settings	<p>Selecting this option will restore the checklist of video formats to its default configuration. Use this option if audio and/or video has been lost after adjusting these settings from their default values.</p> <p>If you are the HDMI connection to your television, the checklist will be automatically customized according to the supported formats reported by the television.</p> <p>If you are using the Component Video (YPbPr) connection to your television, the checklist will have only the <b>1080i</b> and <b>480i</b> formats selected.</p>
Return to Main Menu	Selecting this option will return you to the User Settings Menu main screen.



## Additional HDMI Settings Screen

The Additional HDMI Settings menu is used to configure advanced options that affect the operation of the RNG200N with other HDMI and DVI display devices. Adjustable options include display mode, color space, audio output mode, and audio lip sync delay. The Additional HDMI Settings menu screen is illustrated and defined below.

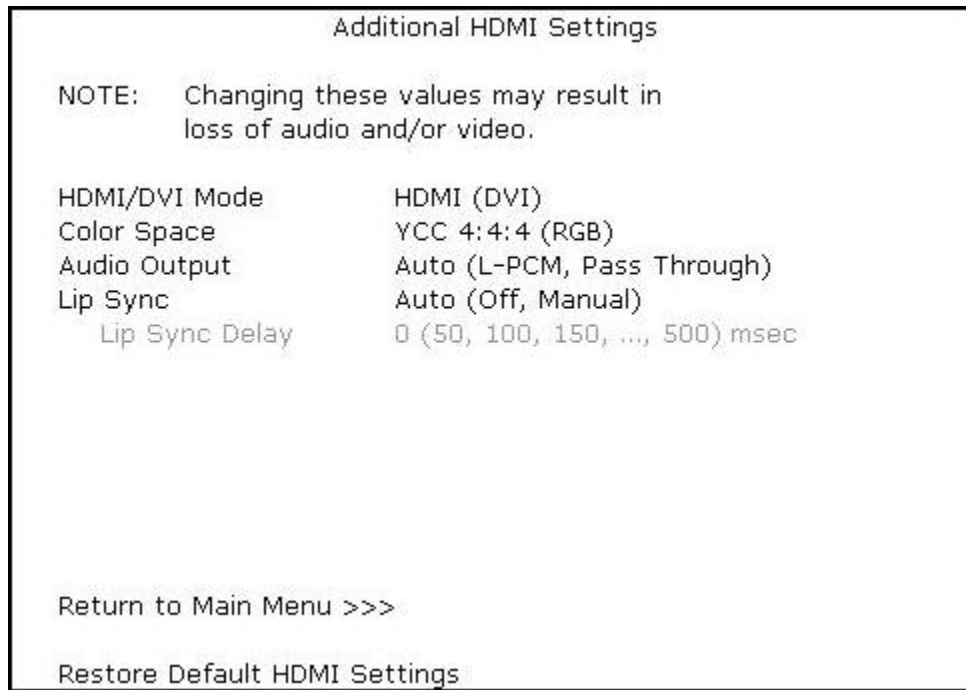

**Additional HDMI Settings screen**

Setting	Description
HDMI/DVI Mode	<p>The <b>HDMI/DVI Mode</b> setting allows you to optimize the HDMI output to work with both DVI-equipped televisions and HDMI-equipped televisions. By default, this option is set to HDMI. The options are used as follows:</p> <ul style="list-style-type: none"> <li>• <b>HDMI</b>—The RNG200N is optimized to work with an HDMI television or home theater receiver.</li> <li>• <b>DVI</b>—The RNG200N is optimized to work with a DVI television or display device (connected via an HDMI-to-DVI adapter).</li> </ul>



Setting	Description
Color Space	<p>The <b>Color Space</b> setting allows you to adjust the color space used by the RNG200N to generate the video signals on the HDMI output. By default, this option is set to <b>YCC 4:4:4</b>. The options are used as follows:</p> <ul style="list-style-type: none"> <li>• <b>YCC 4:4:4</b>—The RNG200N will generate video signals within the YCC color space.</li> <li>• <b>RGB</b>—The RNG200N will generate video signals within the RGB color space.</li> </ul> <p><i>Note: Adjusting these settings could result in a loss of video. Only a professional installer or someone with a good working knowledge of the color spaces supported by the TV should change this setting.</i></p>
Audio Output	<p>The <b>Audio Output</b> setting allows you to specify the digital audio format delivered over the HDMI output by the RNG200N. Options include <b>Auto</b>, <b>L-PCM</b>, and <b>Pass Through</b>. By default, the Auto option is selected. The options are used as follows:</p> <ul style="list-style-type: none"> <li>• <b>Auto</b>—The RNG200N will provide the digital audio format specified by the connected device (TV or home theater receiver) when that device was first connected to the RNG200N.</li> <li>• <b>L-PCM</b>—The RNG200N will provide all audio in the Linear Pulse Code Modulation digital audio format. The L-PCM format is widely supported by most HDMI televisions and home theater receivers.</li> <li>• <b>Pass Through</b>—The RNG200N will provide the same digital audio format on the HDMI output as is provided with the program being viewed at that time. For example, if the program has a Dolby Digital soundtrack, the RNG200N will pass the Dolby Digital audio to the HDMI output. This option is most useful when connecting the RNG200N to a home theater receiver that has HDMI switching capability.</li> </ul> <p><i>Note: Adjusting these settings could result in a loss of audio. Only a professional installer or someone with a good working knowledge of the digital audio formats supported by the TV and/or home theater receiver should change this setting.</i></p>
Lip Sync	<p>The <b>Lip Sync</b> setting allows you to adjust the amount of time the audio signal is delayed with respect to the video signal on the HDMI output. Some HDMI televisions and home theater receivers add an extra delay to the video signal during processing which can produce an effect where the audio noticeably “leads” the video.</p> <p>By default, this option is set to <b>Auto</b>. The options are used as follows:</p> <ul style="list-style-type: none"> <li>• <b>Auto</b>—The RNG200N will automatically delay the audio signal on the HDMI output by the amount of time requested by the connected HDMI device.</li> <li>• <b>Manual</b>—The RNG200N will delay the audio signal on the HDMI output by the amount of time selected for the <b>Lip Sync Delay</b> setting.</li> <li>• <b>Off</b>—The RNG200N will not delay the audio signal on the HDMI output.</li> </ul>
Lip Sync Delay	<p>The <b>Lip Sync Delay</b> setting is only available when the <b>Lip Sync</b> option has been set to <b>Manual</b>. The <b>Lip Sync Delay</b> setting can be adjust between <b>0</b> milliseconds (msec) and <b>500</b> milliseconds in <b>50</b> millisecond increments. If the <b>Lip Sync</b> option has been set to either <b>Auto</b> or <b>Off</b>, this option is disabled and no longer selectable in the menu.</p> <p>Use this option to adjust the HDMI audio delay if you notice that the video image routinely seems to be “behind” the audio soundtrack when using your HDMI device.</p>
Return To Main Menu	<p>Selecting this option will return you to the User Settings Menu main screen.</p>
Restore Default	<p>Selecting this option will restore all of the settings on this screen (<b>HDMI/DVI Mode</b>,</p>



---

Setting	Description
HDMI Settings	<b>Color Space, Audio Output, and Lip Sync</b> ) to their default value. Use this option if audio and/or video has been lost after adjusting these settings from their default values.

---



## Additional Closed Caption Settings Screen

The Additional Closed Caption Settings menu is used to adjust the various display options for closed caption legibility. Customizable options include font size, font style, font color, and font opacity. Users may also select to view different closed caption services if these are included within the broadcast program.

The Additional Closed Caption Settings menu screen is illustrated and defined below.

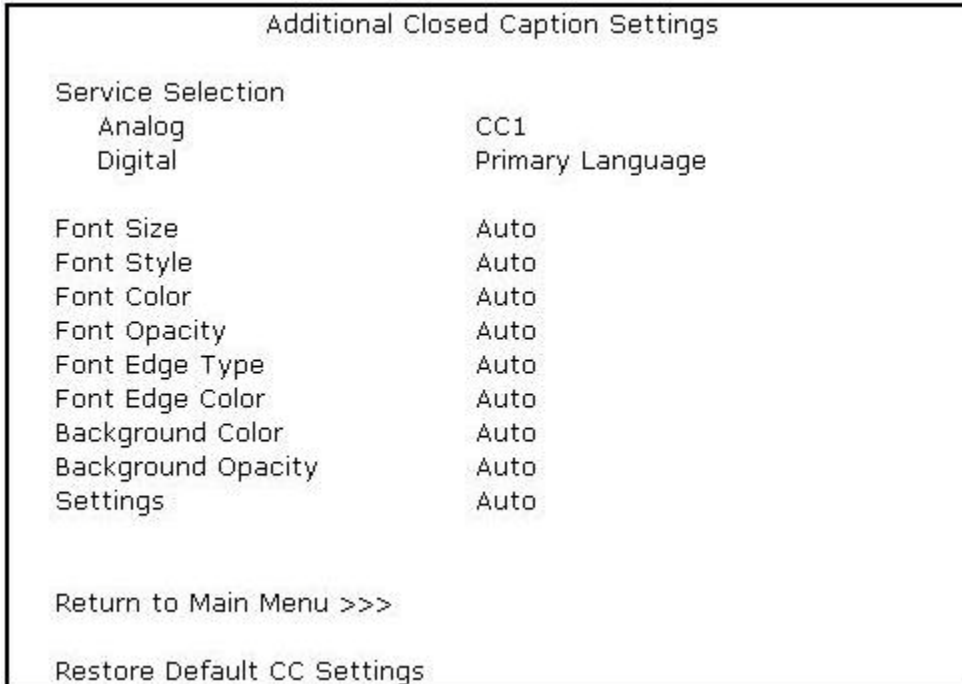

**Additional Closed Caption Settings menu screen**

Setting	Description
Service Selection	Sets the service used by the RNG200N to render (draw) the closed captions: <ul style="list-style-type: none"> <li>• <b>Analog</b>—This setting affects closed captions for analog and digital standard definition services. Available options are: <b>CC1, CC2, CC3, CC4, T1, T2, T3, or T4</b>. The default setting is <b>CC1</b>.</li> <li>• <b>Digital</b>—This setting affects closed captions for digital enhanced definition and high definition services. Available options are: <b>Primary Language, Secondary Language, 3, 4, 5, or 6</b>. The default setting is <b>Primary Language</b>.</li> </ul>
Font Size	Sets the font size used for rendering (drawing) closed captions. The default setting is <b>Auto</b> . Available options include: <b>Auto, Standard, Large, or Small</b> .
Font Style	Sets the font style used for rendering (drawing) closed captions. The default setting is <b>Auto</b> . Available options include: <b>Auto, Mono Serif, Proportion Serif, Mono No Serif, Proportion No Serif, Casual, Cursive, or Small Capitals</b> .



Setting	Description
Font Color	Sets the font color used for rendering (drawing) closed captions. The default setting is <b>Auto</b> . Available options include: <b>Auto, White, Black, Red, Green, Blue, Yellow, Magenta, or Cyan</b> .
Font Opacity	Sets the opacity used for rendering (drawing) closed captions. The default setting is <b>Auto</b> . Available options include: <b>Auto, Transparent, Translucent, Solid, or Flashing</b> .
Font Edge Type	Sets the edge appearance used for rendering (drawing) closed captions. Available options include: <b>Auto, None, Raised, Depressed, Uniform, Left Shadowed, or Right Shadowed</b> . The default setting is <b>Auto</b> .
Font Edge Color	Sets the edge color used for rendering (drawing) closed captions. Available options include: <b>Auto, White, Black, Red, Green, Blue, Yellow, Magenta, or Cyan</b> . The default setting is <b>Auto</b> .
Background Color	Sets the background color used for rendering (drawing) closed captions. The default setting is <b>Auto</b> . Available options include: <b>Auto, White, Black, Red, Green, Blue, Yellow, Magenta, or Cyan</b> .
Background Opacity	Sets the background opacity used for rendering (drawing) closed captions. The default setting is <b>Auto</b> . Available options include: <b>Auto, Transparent, Translucent, Solid, or Flashing</b> .
Settings	Sets the default settings for closed captions ( <b>Auto</b> ) or restores the settings you had previously configured ( <b>User</b> ) allowing you to easily change the closed caption settings between their default settings and your customized settings. The default setting is <b>Auto</b> . Available options include: <b>Auto or User</b> .
Return To Main Menu	Selecting this option will return you to the User Settings Menu main screen.
Restore Default CC Settings	To reset all of the Additional Closed Caption settings to their default values, navigate to this option and press the ► key.





## Subtitle and DVS Settings Screen

The Subtitle and DVS Settings menu is used to customize the language and appearance of subtitles and to turn the descriptive video service feature on and off on the RNG200N. Subtitles allows a viewer to watch television programs and movies which contain dialogue that is not in the viewer's native language. Subtitles are not included within many television programs (unlike closed captions).

A descriptive video service (DVS) is a special secondary audio track which is included within many television programs and is intended to assist the visually impaired. The DVS audio track provides a verbal description of each scene along with the program's normal dialogue.

The Subtitle and DVS Settings menu screen is illustrated and defined below.

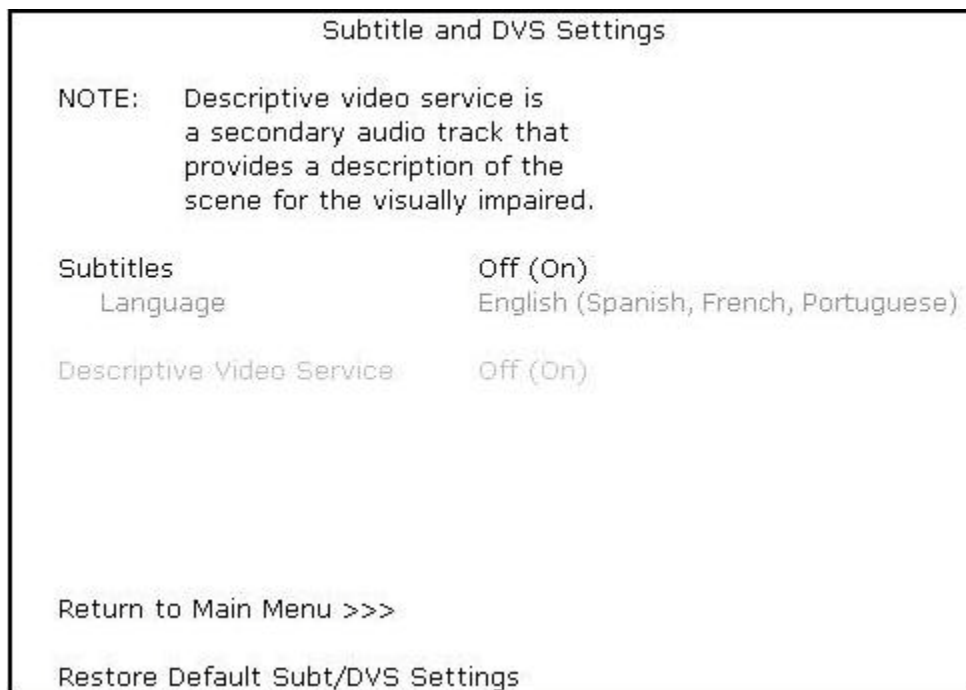

**Subtitle and DVS Settings menu screen**

Setting	Description
Subtitles	<p>The <b>Subtitles</b> default setting is <b>Off</b>. The options are used as follows:</p> <ul style="list-style-type: none"> <li>• <b>Off</b>—Subtitles are not rendered (drawn) by the RNG200N.</li> <li>• <b>On</b>—Subtitles are rendered (drawn) by the RNG200N if they are included within the program and in the language specified by the <b>Language</b> setting.</li> </ul> <p>When the <b>Subtitles</b> option is set to <b>On</b>, the <b>Language</b> selection option becomes selectable from the menu.</p>



Setting	Description
Language	<p>The <b>Language</b> setting is only available when the <b>Subtitles</b> option is set to <b>On</b>. Otherwise, this setting is disabled and no longer selectable in the menu.</p> <p>The default language selection is <b>English</b>. The options are used as follows:</p> <ul style="list-style-type: none"> <li>• <b>English</b>—The RNG200N will render (draw) subtitles in the English language if they are included within the program.</li> <li>• <b>Spanish</b>—The RNG200N will render (draw) subtitles in the Spanish language if they are included within the program.</li> <li>• <b>French</b>—The RNG200N will render (draw) subtitles in the French language if they are included within the program.</li> <li>• <b>Portuguese</b>—The RNG200N will render (draw) subtitles in the Portuguese language if they are included within the program.</li> </ul> <p><i>Note: The RNG200N is not capable of translating subtitles from one language into another language. For example, if French subtitles are included with the program, the RNG200N cannot translate them to into Portuguese if the Language option has been set to Portuguese. The RNG200N can only display subtitles in the language(s) that have been included within the program.</i></p>
Descriptive Video Service	<p>The <b>Descriptive Video Service</b> default setting is <b>Off</b>. The options are used as follows:</p> <ul style="list-style-type: none"> <li>• <b>Off</b>—The DVS audio track is not played by the RNG200N.</li> <li>• <b>On</b>—The DVS audio track is player by the RNG200N if it is included within the program.</li> </ul> <p><i>Note: If the DVS setting is disabled and not selectable from the menu, the software installed on the RNG200N is not capable of supporting the DVS feature.</i></p>
Return To Main Menu	Selecting this option will return you to the User Settings Menu main screen.
Restore Default Subt/DVS Settings	To reset all of the Subtitle and DVS settings to their default values, navigate to this option and press the ► key.



## Advanced Audio/Video Settings Screen

The Advanced Audio/Video Settings menu is used to customize several advanced audio and video features of the RNG200N, most notably the Dolby Volume feature and the Video Sharpness feature.

The Dolby Volume feature provides volume normalization across channels, programs, and commercials. Normalization is a process where the different volume levels across channels, programs, and commercials are adjusted to the same approximate output volume. As a result, sudden volume changes are reduced and the overall volume output of the RNG200N is more consistent.

The Video Sharpness feature is used to soften or sharpen Standard Definition (SD) programs when viewed on either the HDMI or Component Video (YPbPr) outputs. When SD programs are viewed on a large screen television, picture quality can suffer because noise and other imperfections in the picture can be magnified on the large display. The Video Sharpness feature can be used to soften the picture and reduce the appearance of these imperfections.

The Advanced Audio/Video Settings menu screen is illustrated and defined below.

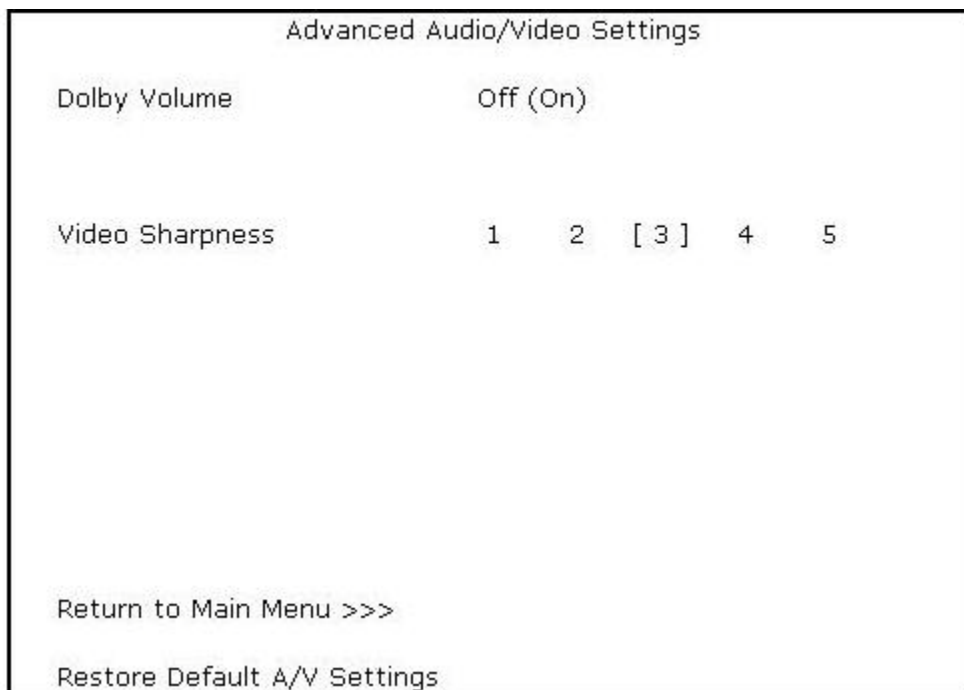

**Advanced Audio/Video Settings menu screen**



Setting	Description
Dolby Volume	<p>The <b>Dolby Volume</b> default setting is <b>Off</b>. The options are used as follows:</p> <ul style="list-style-type: none"> <li>• <b>Off</b>—The Dolby Volume feature is turned off and the output volume may fluctuate during commercials or when changing channels.</li> <li>• <b>On</b>—The Dolby Volume feature is turned on and the RNG200N will maintain a more consistent output volume regardless of the channel or program being viewed.</li> </ul>
Video Sharpness	<p>The <b>Video Sharpness</b> setting allows you to adjust the picture sharpness when viewing a standard definition (SD) program on the RNG200N. The <b>Video Sharpness</b> setting affects the HDMI and Component Video (YPbPr) outputs. By default, the sharpness level of <b>3</b> is selected.</p> <p>The RNG200N supports five distinct levels of analog video picture sharpness. A value of <b>1</b> corresponds to a “softer” picture while a value of <b>5</b> corresponds to a “sharper” picture.</p> <p>The best sharpness setting depends upon the video connection being used, the display quality of the TV, and your own personal preference.</p>
Return To Main Menu	Selecting this option will return you to the User Settings Menu main screen.
Restore Default A/V Settings	To reset all of the Advanced Audio/Video settings to their default values, navigate to this option and press the ► key.



8

# Troubleshooting

Before calling your service provider, review this troubleshooting guide. This information is to help you quickly solve a problem. If your problem still exists, contact your service provider.

Problem	Possible Solution
The RNG set-top will not power on	<p>The RNG set-top may have received a software update and may not power on while the new software is being installed. Try again in a few minutes.</p> <p>Verify that the AC power cord of the external power supply is connected to the RNG set-top and an AC outlet. Unplug the RNG set-top from the AC outlet, plug it back in, and then press the POWER button.</p> <p>If the RNG set-top is connected to a switched outlet on another unit, verify that that unit is powered on. Unplug the power cord from the RNG set-top's AC outlet, plug it back in, and then press the POWER button. Use an unswitched outlet, if possible.</p> <p>Press the POWER button on the RNG set-top front panel instead of the remote control. The batteries in the remote control may be depleted.</p>
The remote control does not work	<p>Verify that the remote control is in "Cable" mode.</p> <p>Verify that there are no obstructions between the remote control and the RNG set-top. Aim the remote control directly at the RNG set-top front panel, not the TV or VCR.</p> <p>The angle between the remote control and the RNG set-top may be too large. Stand in front of the RNG set-top and not too far to either side.</p> <p>Press and release operation keys one at a time, firmly and deliberately.</p> <p>Try changing channels using the buttons on the RNG set-top front panel.</p> <p>Check the batteries in the remote control. Install new batteries if needed.</p>
There is no audio when viewing cable channels	<p>Verify that the mute button on the remote control has not been pressed. Press mute on the remote control to restore sound.</p> <p>If the RNG set-top audio output is connected to the TV, verify that the mute button on the TV has not been pressed.</p> <p>If the RNG set-top audio output is connected to a home theater receiver, verify that the receiver is set to the appropriate input source and the mute button on the receiver has not been pressed.</p> <p>Verify that you have the correct cables for the audio connections.</p> <p>Verify that the audio cables are firmly connected between the RNG set-top and the audio playback device (TV, receiver, DVD player, etc.).</p>
There is no audio from the center and/or surround speakers of a home theater receiver	<p>Not all programs feature full Dolby Digital [5.1] or Dolby Digital Plus [7.1] surround sound. In some cases, the programs may only contain left and right stereo audio.</p> <p>Verify that the S/PDIF cable (coaxial or optical) is firmly connected to the RNG</p>



Problem	Possible Solution
connected to the RNG set-top	<p>set-top and the home theater receiver.</p> <p>Verify that the home theater receiver is set to a surround sound audio mode (Dolby Pro Logic<sup>®</sup>, Dolby Pro Logic II<sup>®</sup>, Dolby Pro Logic IIx<sup>®</sup>).</p> <p>Verify that the receiver is properly configured to work with all connected speakers.</p>
There is no video on the TV screen	<p>Verify that the TV is powered on and set to the appropriate input source for the RNG set-top.</p> <p>Verify that the RNG set-top is powered on and tuned to an authorized cable channel.</p> <p>Verify that all video cables between the RNG set-top and the TV are firmly connected.</p> <p>Verify that the coaxial cable feed is firmly connected to the RNG set-top and the wall jack.</p> <p>If the RNG set-top video output is connected to a home theater unit, verify that the home theater unit is powered on and set to the appropriate input source.</p> <p>If the RNG set-top video output is connected to a TV through an HDMI connection, power off the TV and then power off the RNG set-top. Wait one second and then power on the devices.</p> <p>Not all HDTVs can display every output format (1080p60, 1080p30, 1080p24, 1080i, 720p, 480p, or 480i) available on the RNG set-top. To select a different format:</p> <ul style="list-style-type: none"> <li>• Ensure that your RNG set-top is plugged into a power outlet and is turned off.</li> <li>• Press the MENU key on the front panel. Your settings are displayed on the RNG set-top front panel display.</li> <li>• Press the ▲ and ▼ keys to display the HDMI/YPbPr OUTPUT setting.</li> <li>• Press the ► key to cycle through the available output formats until a picture displays on the TV.</li> </ul>
No graphics or program guides appear on the TV screen	<p>If you use the IEEE-1394 connection, on-screen graphics, including closed captions and program guides, are not displayed by the RNG set-top. On-screen graphics and captions may still be overlaid by your TV, if enabled. Alternatively, use HDMI or component video instead.</p>
No closed captions display	<p>Verify on the User Settings menu that closed captions are enabled on the RNG set-top.</p> <p>Verify that closed captions are enabled on the TV.</p> <p>Note: Closed captioning may not be available on the current program.</p>



Problem	Possible Solution
<p>There are black bars to the right and left of the picture</p>	<p>Wide screen TVs display 4:3 programs in this format unless set to Stretch. Turn on the 4:3 OVERRIDE feature in the User Settings menu. This enables most wide screen TVs to stretch the video to fill the screen (see your TV manual for information about stretching 4:3 video).</p> <p>If the RNG set-top is connected to a wide screen TV, verify that the TV TYPE is set to 16:9 in the User Settings menu.</p> <p>Many HD programs are broadcast in pillar-box format with black bars to the left and right of the picture. These programs are broadcast in 16:9 HD formats even though the video is not 16:9.</p>
<p>There are black bars above and below the picture</p>	<p>All 4:3 HDTVs display HD programs in letterbox format (black bars above and below the picture) because of the shape of the display screen.</p> <p>Turn on the 4:3 OVERRIDE feature in the User Settings menu. This enables most standard screen TVs to display a full screen picture when the RNG set-top is tuned to a 4:3 program.</p> <p>Set the TV TYPE to 4:3 Pan-Scan. This enables the RNG set-top to remove the black bars above and below the picture when possible.</p> <p>Some SD programs are broadcast in the letterbox format with black bars above and below the picture. Some widescreen TVs offer a zoom feature that may be able to remove the black bars (see your TV manual for information about zooming 4:3 video).</p>
<p>There are black bars on all four sides of the picture</p>	<p>This may occur on a 4:3 TV if the 4:3 OVERRIDE setting is OFF. To set 4:3 SD programming to fill the screen, depending on the capabilities of the TV, set 4:3 OVERRIDE to 480i or 480p.</p> <p>This may occur on a 16:9 TV if the active video for an SD broadcast is in letterbox format. To confirm, wait for a commercial or look for a graphic, such as a network logo. If the commercial fills the screen from top to bottom, or the graphic appears below the active video, the program is being letterboxed by the broadcaster. You can minimize this by activating the zoom feature on the TV.</p> <p>A broadcaster may include black bars on either side of a wide screen broadcast. This is called a “hybrid” aspect ratio and results in a black border surrounding the video on a 4:3 TV. Because this is part of the broadcast, the RNG set-top cannot correct the video. You may be able to minimize the border using the zoom feature on the TV.</p>
<p>Colors do not appear correctly</p>	<p>Be sure to match up each signal to the same YPbPr connection on the TV, otherwise the colors will not appear correctly on your TV.</p>
<p>The RNG set-top is making a humming noise.</p>	<p>The RNG set-top includes an integrated hard drive and a fan for cooling. During normal operation, the RNG set-top emits a low humming noise, similar to a personal computer. The noise varies in volume occasionally when the speed of the internal fan adjusts to changes in the temperature around the RNG set-top. Please note the hard drive will stay on even when the RNG set-top is turned off (standby).</p>



**MOTOROLA**

Motorola Mobility, Inc.  
101 Tournament Drive, Horsham, PA 19044 [www.motorola.com](http://www.motorola.com)

365-095-16097 x.1 12/10

