

# DCTI 800

## User Guide

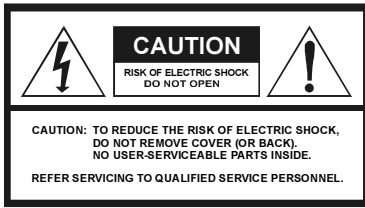



Graphical symbols and supplemental warning marking locations on bottom of terminal.

**WARNING**

TO PREVENT FIRE OR SHOCK HAZARD, DO NOT EXPOSE THIS APPLIANCE TO RAIN OR MOISTURE.

**CAUTION**

TO PREVENT ELECTRICAL SHOCK, DO NOT USE THIS (POLARIZED) PLUG WITH AN EXTENSION CORD, RECEPTACLE, OR OTHER OUTLET UNLESS THE BLADES CAN BE FULLY INSERTED TO PREVENT BLADE EXPOSURE.



The lightning flash with arrowhead symbol, within an equilateral triangle, is intended to alert the user to the presence of uninsulated "dangerous voltage" within the product's enclosure that may be of sufficient magnitude to constitute a risk of electric shock to persons.



The exclamation point, within an equilateral triangle, is intended to alert the user to the presence of important operating and maintenance (servicing) instructions in the literature accompanying the appliance.

This installation should be made by a qualified service person and should conform to all local codes.

**REPAIRS**

If you find the unit in need of repair, contact your cable system operator for repair or replacement.

**NOTE TO CATV SYSTEM INSTALLER**

This reminder is provided to call the CATV system installer's attention to Article 820-40 of the NEC that provides guidelines for proper grounding and, in particular, specifies that the cable ground shall be connected to the grounding system of the building, as close as possible to the point of cable entry as practical.

**EXAMPLE OF ANTENNA GROUNDING**

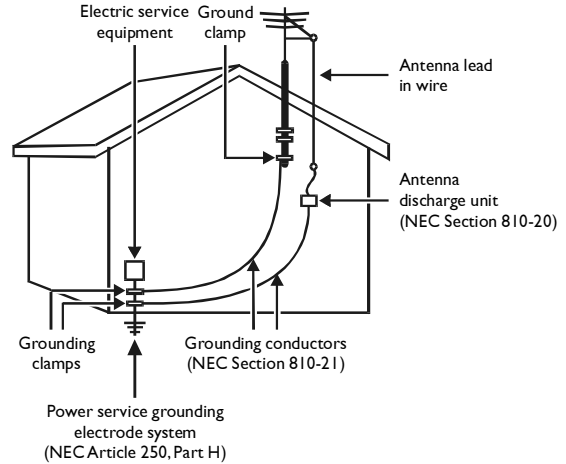

NEC=NATIONAL ELECTRICAL CODE

# Important Safety Instructions

## **1 Read instructions**

All the safety and operating instructions should be read before the appliance is operated.

## **2 Retain instructions**

The safety and operating instructions should be retained for future reference.

## **3 Heed warnings**

All warnings on the appliance and in the operating instructions should be adhered to.

## **4 Follow instructions**

All operating and use instructions should be followed.

## **5 Cleaning**

Unplug this product from the wall outlet before cleaning. Do not use liquid cleaners or aerosol cleaners. Use a damp cloth for cleaning.

## **6 Attachments**

Do not use attachments not recommended as they may cause hazard.

## **7 Water and moisture**

Do not use this equipment near water; for example, near a bath tub, wash bowl, kitchen sink, or laundry tub, in a wet basement, or near a swimming pool, and the like.

## **8 Accessories**

Do not place this product on an unstable cart, stand, tripod, bracket, or table. The product may fall causing serious injury and serious damage to the appliance. Use only with a cart, stand, tripod, bracket, or table recommended by the manufacturer, or sold with the equipment. Any mounting of the appliance should follow the manufacturer's instructions, and should use a mounting accessory recommended by the manufacturer.

## **9 Ventilation**

Slots and openings in the cabinet are provided for ventilation and to ensure reliable operation of the equipment and to protect it from overheating. The openings should never be blocked by placing the product on a bed, sofa, rug, or similar surface. Equipment should never be placed near or over a radiator or heat register, or in a built-in installation such as a bookcase or rack unless proper ventilation is provided.

## **10 Power sources**

This product should be operated only from the type of power sources indicated on the marking label. If you are not sure of the type of power supplied to your home, consult your local power company. For equipment intended to operate from battery power, or other sources, refer to the operating instructions.

## **11 Ground or polarization**

This equipment may be equipped with a polarized alternating-current line plug (a plug having one blade wider than the other). This plug will fit into the power outlet only one way. This is a safety feature. If you are unable to insert the plug fully into the outlet, try reversing the plug. If the plug should still fail to fit, contact your electrician to replace your obsolete outlet. Do not defeat the safety purpose of the polarized plug.

## **12 Alternate warnings**

This equipment may be equipped with a 3-wire grounding-type plug, a plug having a third (grounding) pin. This pin will only fit into a grounding-type power outlet. This is a safety feature. If you are unable to insert the plug into the outlet, contact your electrician to replace your obsolete outlet. Do not defeat the safety purpose of the grounding-type plug.

## **13 Power cord protection**

Power supply cords should be routed so that they are not likely to be walked on or pinched by items placed upon or against them, paying particular attention to cords at plugs, convenience receptacles, and the point where they exit from the appliance.

## **14 Outdoor Antenna Grounding**

If an outside antenna or cable system is connected to the equipment, be sure the antenna or cable system is grounded as to provide some protection against voltage surges and built-up static charges.

## **15 Lightning**

For added protection for this equipment during a lightning storm, or when it is left unattended and unused for long periods of time, unplug it from the wall outlet and disconnect the antenna or cable system. This will prevent damage to the video product due to lightning and power line surges.

## **16 Power lines**

An outside antenna system should not be located in the vicinity of overhead power lines or where it can fall into such power lines or circuits. When installing an outside antenna system, extreme care should be taken to keep from touching such power lines or circuits, as contact with them may be fatal.

## **17 Overloading**

Do not overload wall outlets and extension cords as this can result in a risk of fire or electrical shock.

## **18 Object and liquid entry**

Never push objects of any kind into this equipment through openings as they may touch dangerous voltage points or short-out parts that could result in a fire or electrical shock. Never spill liquid of any kind on the product.

## **19 Servicing**

Do not attempt to service this equipment yourself as opening or removing covers may expose you to dangerous voltage or other hazards, refer all servicing to qualified service personnel.

## **20 Damage requiring service**

Unplug this equipment from the wall outlet and refer servicing to qualified service personnel under the following conditions:

- a** When the power supply cord or plug is damaged.
- b** If the equipment has been exposed to rain or water.
- c** If liquid has been spilled, or objects have fallen into the equipment.
- d** If the equipment does not operate normally by following the operating instructions. Adjust only those controls that are covered by the operating instructions as an improper adjustment of other controls may result in damage and will often require extensive work by a qualified technician to restore the equipment to its normal operation.
- e** If the equipment has been dropped or cabinet has been damaged.
- f** When the equipment exhibits a distinct change in performance, indicating a need for service.

## **21 Replacement parts**

When replacement parts are required, be sure the service technician has used replacement parts specified by the manufacturer or have the same characteristics as the original part. Unauthorized substitutions may result in fire, electric shock, or other hazards.

## **22 Safety check**

Upon completion of any service or repairs to this video product, ask the service technician to perform safety checks to determine that the product is in proper operational condition.

## **23 Heat**

The product should be situated away from heat sources such as radiators, heat registers, stoves, or other products (including amplifiers) that produce heat.

## **24 Battery usage**

Notwithstanding any information provided by Motorola in this manual regarding the use of batteries, the end user assumes all responsibility and liability to use and dispose of batteries in accordance with all applicable laws, rules and regulations. Motorola will not be liable to anyone for the end user's failure to use and/or dispose of batteries in the proper manner and in accordance with such laws, rules and regulations, or for any defect contained in batteries that may cause injury damage to persons or property.

## Regulatory Information

Federal Communications Commission Radio and Television Interface Statement for a Class 'B' Device

This equipment has been tested and found to comply with the limits for a Class B digital device, pursuant to part 15 of the FCC Rules. These limits are designed to provide reasonable protection against harmful interference in the residential installation. This equipment generates, uses and can radiate radio frequency energy and, if not installed and used in accordance with the instructions, may cause harmful interference to radio communications. However, there is no guarantee that interference will not occur in a particular installation.

If the equipment does cause harmful interference to radio or television reception, which can be determined by turning the equipment off and on, the user is encouraged to try to correct the interference by one of the following measures:

- Increase the separation between the equipment and the affected receiver
- Connect the equipment on a circuit different from the one the receiver is on
- Ensure that the cover plate for the security card is secured and tight

Changes or modification not expressly approved by the party responsible for compliance could void the user's authority to operate the equipment.

## Declaration of Conformity

According to 47 CFR, Parts 2 and 15 for Class B Personal Computers and Peripherals; and/or CPU Boards and Power Supplies used with Class B Personal Computers, Motorola, Inc., 6450 Sequence Drive, San Diego, CA 92121, 1-800-225-9446, declares under sole responsibility that the product identifies with 47 CFR Part 2 and 15 of the FCC Rules as a Class B digital device. Each product marketed is identical to the representative unit tested and founded to be compliant with the standards. Records maintained continue to reflect the equipment being produced can be expected to be within the variation accepted, due to quantity production and testing on a statistical basis as required by 47 CFR 2.909. Operation is subject to the following condition: This device must accept any interference received, including interference that may cause undesired operation. The above named party is responsible for ensuring that the equipment complies with the standards of 47 CFR, Paragraphs 15.107 to 15.109.

## Canadian Compliance

This Class B digital apparatus meets all requirements of the Canadian Interference-Causing Equipment Regulations. Cet appareil numérique de la classe B respecte toutes les exigences du Règlement sur le matériel brouilleur du Canada.

---

Copyright © 2003 Motorola, Inc.

All rights reserved. No part of this publication may be reproduced in any form or by any means or used to make any derivative work (such as translation, transformation or adaptation) without written permission from Motorola, Inc.

Motorola reserves the right to revise this publication and to make changes in content from time to time without obligation on the part of Motorola to provide notification of such revision or change. Motorola provides this guide without warranty of any kind, either implied or expressed, including but not limited to, the implied warranties of merchantability and fitness for a particular purpose. Motorola may make improvements or changes in the product(s) described in this manual at any time.

MOTOROLA and the Stylized M Logo are registered in the US Patent & Trademark Office. Dolby Surround is a registered trademark of Dolby Laboratories Licensing Corporation. All other product or service names are the property of their respective owners.

# CONTENTS

**Introduction ..... 2**

**Using the Remote Control ..... 6**

    Installing Batteries ..... 10

**Basic Operation ..... 11**

    Turning Power On and Off..... 11

    Changing Channels..... 11

    Adjusting the Volume ..... 11

**Basic Operation .....12**

    Electronic Program Guide..... 12

**Audio/Video Connections .....13**

**Connecting your DCT1800 ..... 14**

    Standard TV Cabling ..... 14

    Standard VCR Cabling ..... 15

    Composite Baseband ..... 16

    Composite VCR Cabling..... 17

    Stereo Cabling Diagram (VCR to Stereo)..... 18

    Stereo Cabling Diagram (TV to Stereo) ..... 19

**Troubleshooting ..... 20**

## INTRODUCTION

*The DCT1800 requires a Motorola universal remote control (sold separately).*

*The DCT1800 can offer one or more of the following features accessible only through the remote control:*

- *Parental control*
- *Favorite channel recall*
- *Volume control*
- *Easy Pay-Per-View purchases*
- *Electronic program guide (EPG)*
- *Video on Demand*

Congratulations on receiving the DCT1800 digital consumer terminal, one of the most advanced interactive digital cable terminals available today. It's simple to set up and easy to operate.

The DCT1800 can provide an Electronic Program Guide (EPG) menu that allows you to conveniently select and view programs. You can also purchase Pay-Per-View special events, recent movies, or Video on Demand. Video on Demand is similar to renting a video, including the ability to pause, rewind, and fast-forward.

This guide introduces you to the features and operation of the DCT1800. Access to the DCT1800 features is gained through the electronic program guide.

*To get the most out of your DCT1800, be sure to read your electronic program guide instruction manual and Motorola universal remote control User Guide.*



## NOTE

*The DCT1800 requires a Motorola universal remote control to operate.*

## Front Panel

The DCT1800 is controlled by your Motorola universal remote control (sold separately). The front panel has two LED displays: one to indicate the unit is turned on and one to indicate a message is present.

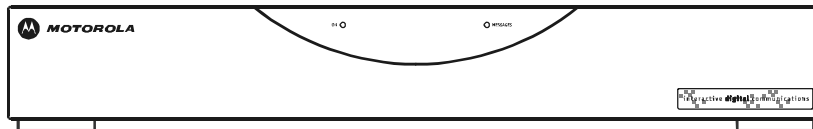



## Rear Panel

Before you begin installing the DCT1800, take a moment to become familiar with the rear panel connections. The rear panel connectors are for system cabling, and an AC power cord connects the DCT1800 to an electrical power outlet. For cabling diagrams, see “Connecting Your DCT1800”.

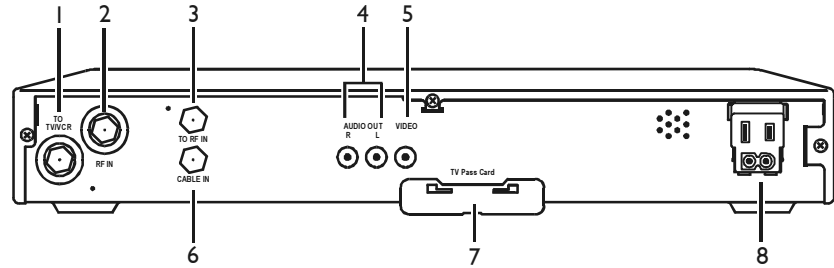

# INTRODUCTION

	Item	Description
1	<b>TO TV/VCR</b>	A coaxial output to connect the DCT1800 to the TV or VCR.
2	<b>RF IN</b>	A coaxial input that is connected to the TO RF IN, see Connecting the DCT1800.
3	<b>TO RF IN</b>	A coaxial input that directs the cable signal to other connections on the DCT1800.
4	<b>AUDIO OUT</b>	Left/right audio outputs to connect the DCT1800 to a TV, VCR, or A/V receiver.
5	<b>VIDEO</b>	Composite video output to connect the DCT1800 to a TV, VCR, or A/V receiver.
6	<b>CABLE IN</b>	A coaxial input for the incoming signal from the wall outlet.
7	<b>TV Pass Card slot</b>	This space is reserved for future use.
8	<b>AC power</b>	This is a two-plug AC power connection. The bottom plug is for attaching a power cord. The top plug can be configured for plugging in another device such as a TV or VCR.

# USING THE REMOTE CONTROL

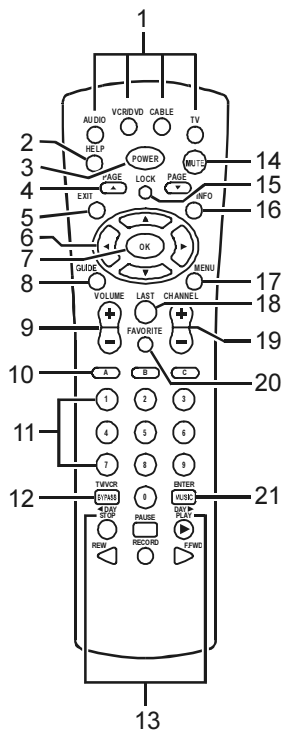

Use the Motorola universal remote control to operate the DCT1800, TV, and VCR.

*Your remote control may differ from the Motorola DRC450 Universal Remote Control illustrated here.*

*The Motorola universal remote control must be programmed for use. If your service provider has not programmed your remote control, refer to the remote control User Guide supplied by your service provider.*

## USING THE REMOTE CONTROL

	<b>Key</b>	<b>Description</b>
<b>1</b>	<b>AUDIO, VCR/DVD, CABLE, OR TV</b>	Selects a device to control. The selected mode will remain active until you press another key.
<b>2</b>	<b>HELP</b>	Displays the help screen.
<b>3</b>	<b>POWER</b>	Turns the currently selected device on or off.
<b>4</b>	<b>PAGE ▲ PAGE ▼</b>	Pages through menu screens and the program guide.
<b>5</b>	<b>EXIT</b>	Exits a menu or program guide.
<b>6</b>	<b>◀ ▲ ▶ ▼ CURSOR</b>	Moves the cursor around the program guide and menu screens.
<b>7</b>	<b>OK</b>	Selects menu options, Pay-Per-View events or programs from the program guide.
<b>8</b>	<b>GUIDE</b>	Displays the program guide.
<b>9</b>	<b>VOLUME + VOLUME -</b>	Increases or decreases the volume of the currently selected device.

## USING THE REMOTE CONTROL

	<b>Key</b>	<b>Description</b>
<b>10</b>	<b>A B C</b>	Functionality is determined from services offered by your cable TV service provider.
<b>11</b>	<b>NUMBER KEYS</b>	Use to directly select a channel.
<b>12</b>	<b>TV/VCR or BYPASS</b>	When in VCR mode, toggles between television and VCR. Bypass is not currently available.
<b>13</b>	<b>STOP, PAUSE, PLAY, REW, RECORD, F.FWD</b>	Controls the VCR/DVD or CD player.
<b>14</b>	<b>MUTE</b>	Toggles the sound on and off.
<b>15</b>	<b>LOCK</b>	Use to limit viewing of selected programs or to view the Pay-Per-View menu.
<b>16</b>	<b>INFO</b>	Displays the current channel and program information (not supported by all applications).
<b>17</b>	<b>MENU</b>	Displays the main menu.
<b>18</b>	<b>LAST</b>	Recalls the last channel or goes back one screen in the menu.
<b>19</b>	<b>CHANNEL + CHANNEL -</b>	Changes the channels by moving up or down.

## USING THE REMOTE CONTROL

<b>Key</b>	<b>Description</b>
<b>20 FAVORITE</b>	Displays preset favorite cable channels.
<b>21 ENTER/MUSIC</b>	Displays digital music channel menus. On some TV models, press to enter channels.

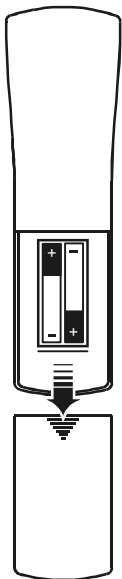

### Installing Batteries

Before you can use the remote control, you must install two AA (1.5-volt) alkaline batteries (provided with your Motorola universal remote control):

- 1** Slide open the battery door on the back of the remote control.
- 2** Insert the batteries in the direction indicated on the inside of the battery compartment.

*Batteries installed incorrectly can cause battery leakage and corrosion that will damage the remote control.*

- 3** Slide the battery door closed until it snaps into place.

Point the remote control at the DCT1800, and then press POWER. If the DCT1800 does not turn on, check the orientation of the batteries or replace with new batteries.

*Your remote control may be different from the Motorola DRC450 Universal Remote Control illustrated here. Refer to the remote control User Guide for details on installing batteries.*



### NOTE

*The DCT1800 requires a Motorola universal remote control to operate.*

## Turning Power On and Off

To turn the DCT1800 on or off, be sure it is in cable mode by pressing CABLE on your remote control and then press POWER.

## Changing Channels

Be sure the remote control is in CABLE mode and enter the number of the channel you want to tune using the numeric keys, or press CHANNEL + or – on the remote control to step through the channel selection.

## Adjusting the Volume

Press VOLUME + or – on the remote control to adjust the volume. When you adjust the volume, the volume scale is displayed on the screen. Press MUTE on the remote control to turn the sound off and on again.

For best audio quality, use the remote control to set the DCT1800 to approximately  $\frac{3}{4}$  of the maximum volume level and then adjust the audio levels on the external devices such as your television.



### **Electronic Program Guide**

The electronic program guide displays information about TV programs and enables you to access features such as Parental Control or Pay-Per-View. Electronic program guides can vary in look and feel with each service provider. Reference the electronic program guide instruction manual for detailed instructions.

## AUDIO/VIDEO CONNECTIONS



### NOTE

*It is important to remember not to place anything on top of the DCT1800 and to provide for adequate ventilation to prevent overheating.*

Before you begin to hook up your DCT1800, review the following:

- For basic cable connections, use 75-ohm coaxial cables equipped with F-type connectors. You can find coaxial cables in your local electronics store.
- For audio or video outputs, use cables equipped with RCA-type connectors.
- Disconnect power from the DCT1800 before connecting or changing cable connections.
- **Do not** place anything on top of the DCT1800, especially other home video components.

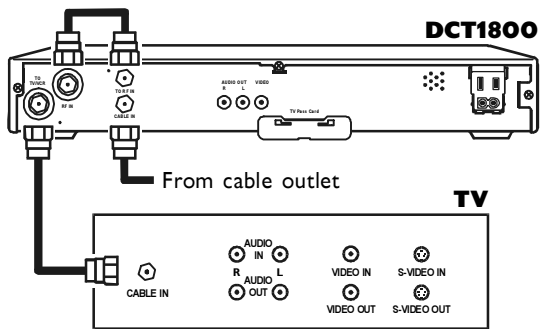

## Standard TV Cabling

Use 75-ohm coaxial cables to connect your DCT1800 to a TV. This is the most common cable connection, and it provides all of the basic features of the DCT1800.

If you are using a diagram that connects the coaxial TO TV/VCR connector on the DCT1800 to the coaxial CABLE IN connector on the TV, you must tune your TV to channel 3 or 4.

*The illustrated connections will not provide stereo on digital channels. Connect the DCT1800 using RCA baseband connectors to receive stereo on digital channels (illustrated later in this section).*

# CONNECTING YOUR DCT1800

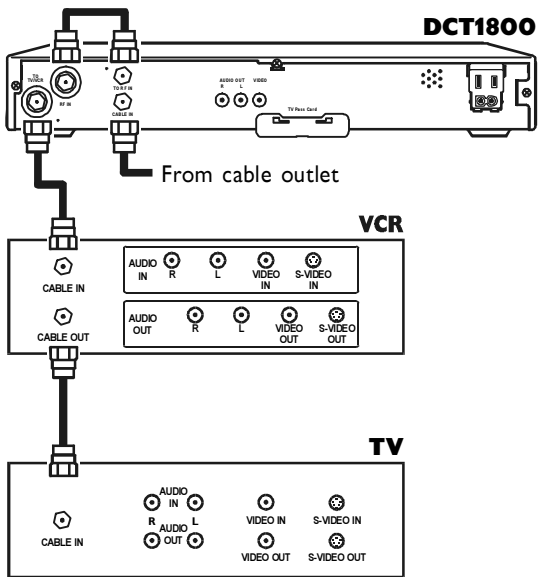

## Standard VCR Cabling

To connect your VCR, you will need 75-ohm coaxial cables. The illustrated VCR connection enables you to record the program you are watching, including Pay-Per-View events. You can also view videotapes just as you do now.

*The illustrated connections will not provide stereo on digital channels. Connect the DCT1800 using RCA baseband connectors to receive stereo on digital channels (illustrated later in this section).*

# CONNECTING YOUR DCT1800

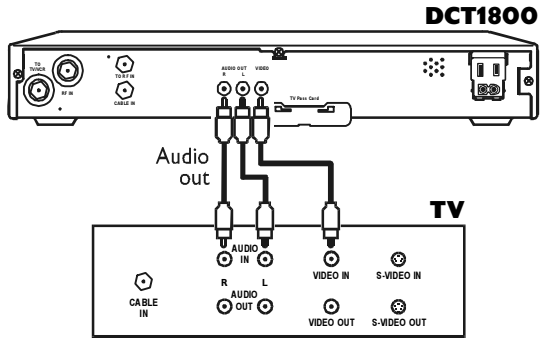

In these illustrations the baseband connectors on entertainment components are labeled R for right audio, L for left audio, and V or VIDEO.

## Composite Baseband

Connecting the DCT1800 using the RCA-type baseband outputs enables you to experience stereo and Dolby Surround<sup>®</sup> sound on digital channels when available.

# CONNECTING YOUR DCT1800

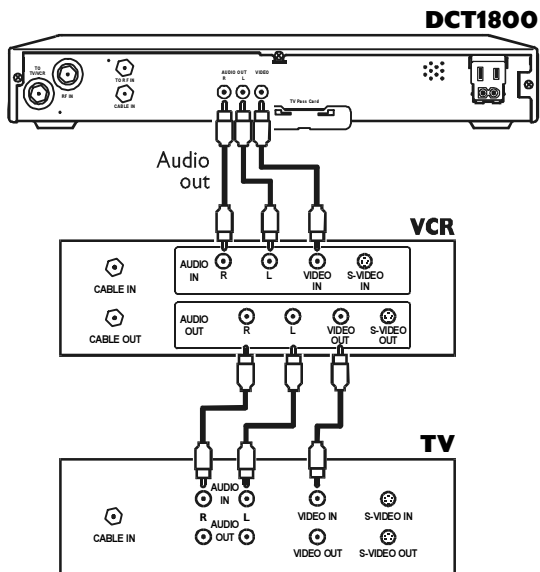

## Composite VCR Cabling

This diagram illustrates how to connect the DCT1800 to a VCR using the audio connectors on the VCR.

# CONNECTING YOUR DCT1800

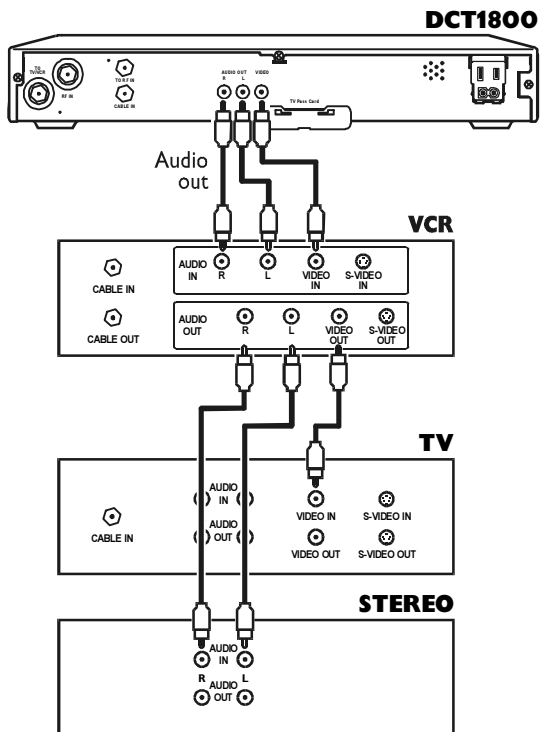

## Stereo Cabling Diagram (VCR to Stereo)

This diagram illustrates how to connect the DCT1800 to a stereo using the audio connectors on the VCR. The VCR sound is played through the stereo.

# CONNECTING YOUR DCT1800

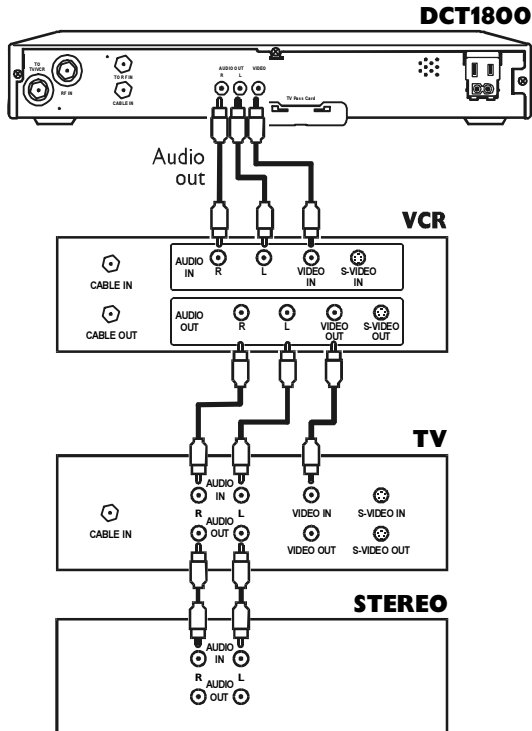

## Stereo Cabling Diagram (TV to Stereo)

This diagram illustrates how to connect the TV to a stereo using the audio connectors on the DCT1800. The TV sound is played through the stereo.



## TROUBLESHOOTING

Before calling your service provider, review the troubleshooting guide. This information is to help you quickly solve a problem. If your problem still exists, contact your service provider.

<b>Problem</b>	<b>Possible Solution</b>
<b>No sound</b>	<p>Press MUTE on the remote control to restore the volume level.</p> <p>Check that the stereo is set to the proper input source.</p> <p>Turn on your VCR.</p> <p>Make sure the TV or stereo volume is set to an appropriate level. For best audio level control, use the remote control to set the DCT1800 to approximately <math>\frac{3}{4}</math> of the maximum volume level and then adjust the audio levels of the external devices.</p>
<b>No picture</b>	<p>Check to be sure that all cables are connected properly (hand-tighten if necessary).</p> <p>If connected through the baseband RCA video connection, make sure the cables are connected properly.</p> <p>If you are watching TV using your VCR, be sure your VCR is powered and running.</p>
<b>Picture or sound is noisy on one channel</b>	<p>Reconnect the cable and hand-tighten if loose.</p>
<b>Sound from only one stereo speaker</b>	<p>Hand-tighten or reconnect the cables properly. Be sure wires are not frayed and plugs are not bent or broken.</p>

## TROUBLESHOOTING

<b>Problem</b>	<b>Possible Solution</b>
<b>No power</b>	Reconnect the power cord. Be sure the DCT I 800 is plugged into an outlet that is always live.
<b>Remote control does not work</b>	Press CABLE on the remote control to ensure the remote control is in cable mode.  Change the batteries in your remote control according to the instructions in the section, "Installing Batteries."  Be sure that nothing is on the DCT I 800 or blocking a clear line of sight between it and the remote control.



**505974-001**

**2/03**

**English**

**MGBI**

