

## WELCOME

### Connecting your RNG110

#### 1. Decide which connections work best with your equipment.

Depending on the type of TV and other equipment you have, choose the connections that will provide the best quality video and audio. Refer to your equipment user manuals and the tables provided in this guide.

#### 2. Connect your RNG110 to your cable service.

Connect the cable from your cable wall outlet to the **CABLE IN** connector on the rear panel of your RNG110.

#### 3. Connect the RNG110 to your TV and other equipment.

Once you have decided which audio and video connections you need to make, refer to the illustrations in this guide to connect your RNG110 to your TV and other A/V equipment.

#### 4. Turn on your RNG110.

Plug the 5-volt cord from the power supply unit into the power input socket (labelled **DC IN +5V**) on the rear panel of your RNG110, then plug the power supply unit into the wall AC outlet using the power cord supplied.

Press the **POWER** button on your remote control - the RNG110 will turn on.

#### 5. Enjoy digital TV!

Use the User Settings menu (see below) to fine-tune your setup. Any problems? Refer to the Troubleshooting section of this guide and to your equipment user manuals.

For further information on setting up and operating your set-top, refer to the RNG110 Operator's Manual, available at <http://comcast.com>

## IMPORTANT SAFETY INSTRUCTIONS

Before you install or use the apparatus, you must read and understand these Important Safety Instructions. At all times when using the apparatus you must follow these Important Safety Instructions to reduce the risk of fire, electrical shock and injury to persons.

1. Read these instructions.
2. Keep these instructions.
3. Heed all warnings.
4. Follow all instructions.
5. Do not use this apparatus near water.
6. Clean only with dry cloth.
7. Do not block any ventilation openings. Install in accordance with the manufacturer's instructions.
8. Do not install near any heat sources such as radiators, heat registers, stoves, or other apparatus (including amplifiers) that produce heat.
9. Do not defeat the safety purpose of the polarized or grounding-type plug. A polarized plug has two blades with one wider than the other. A grounding type plug has two blades and a third grounding prong. The wide blade or the third prong are provided for your safety. If the provided plug does not fit into the outlet, consult an electrician for replacement of the obsolete outlet.
10. Protect the power cord from being walked on or pinched particularly at plugs, convenience receptacles, and the point where they exit from the apparatus.
11. Only use attachments/accessories specified by the manufacturer.
12. Use only with the cart, stand, tripod, bracket, or table specified by the manufacturer, or sold with the apparatus. When a cart is used, use caution when moving the cart/apparatus combination to avoid injury from tip-over.
13. Unplug this apparatus during lightning storms or when unused for long periods of time.
14. Refer all servicing to qualified service personnel. Servicing is required when the apparatus has been damaged in any way, such as power-supply cord or plug is damaged, liquid has been spilled or objects have fallen into the apparatus, the apparatus has been exposed to rain or moisture, does not operate normally, or has been dropped.



#### Additional safety information

- To disconnect power from the set-top, always remove its power supply unit from the AC mains supply (rather than disconnect the 5 volt cord from the set-top). Therefore you must install your set-top near to the wall AC outlet, which should be easily accessible.
- Do not perform any servicing unless you are qualified to do so by the manufacturer. Refer all servicing to qualified service personnel. Servicing the set-top yourself will invalidate the warranty.
- Maintain a minimum distance of three inches around your set-top for sufficient ventilation.
- To reduce the risk of fire or electric shock, do not expose this set-top to rain or moisture.
- The model number, serial number and electrical rating of your set-top are on a label on its base.

## RNG110

### High-definition digital set-top

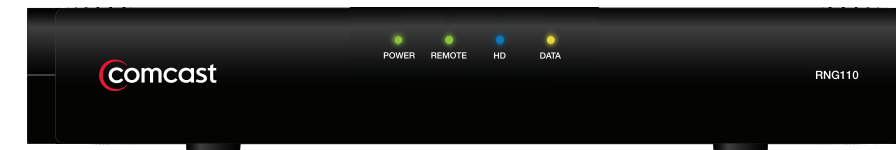

## Quick Start Guide

#### Standard-definition video connections (SDTV)

Video quality	TV video input	RNG110 video output	Includes audio?
Standard	Composite Video	VIDEO OUT	No

#### High-definition video connections (HDTV)

Video quality	TV video input	RNG110 video output	Includes audio?
Top	HDMI®	HDMI	Yes
	DVI	HDMI	No
Superior	IEEE-1394	1394	Yes
High	Component (YPbPr)	COMPONENT VIDEO	No

#### Alternate audio connections

Audio quality	Audio connections
Top	OPTICAL AUDIO OUT (S/PDIF)
High	AUDIO OUT (stereo L and R)

**Note:** If you use the optional RF connections (shown by dashed lines in the setups overleaf), you must tune your TV (and VCR) to your set-top's VHF output channel (3 or 4: consult your cable service provider to find which channel it is for your location). Consult the manuals supplied with your TV and VCR for information on RF tuning.

## SET-TOP SETUP

You can use the **USER SETTINGS** menu to change your set-top's setup. The settings you can change are shown in the table below.

1. Make sure your set-top is turned on (the POWER light is green).
2. Press the **POWER** button on your remote control, then press the **Menu** button. The USER SETTINGS menu is displayed on your screen.
3. Use the **Left**, **Right**, **Up**, and **Down** buttons to navigate the menus and the **OK/Select** button to confirm your choices. See the example below.
4. Press **POWER** to remove the menu and return to normal viewing.

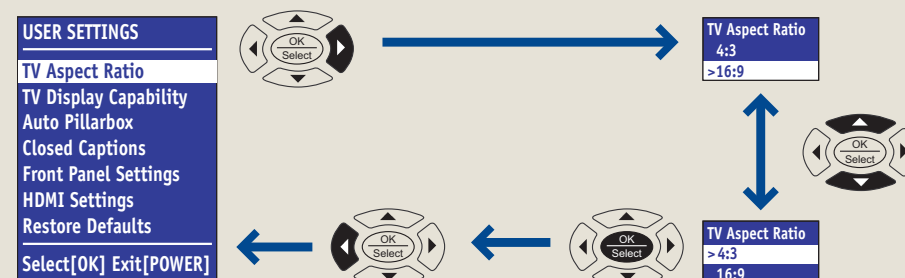

Menu item	Description	Options*
TV Aspect Ratio	Choose your TV screen's shape	4:3 or <b>16:9</b>
TV Display Capability	Choose the screen resolutions your TV is capable of displaying	<b>1080i</b> , 720p, <b>480p</b> , <b>480i</b> , 1080p24 Pass, and/or 1080p30 Pass
Auto Pillarbox	If your 16:9 TV doesn't automatically detect programs transmitted in 4:3, choose to have black bars added to the sides of 4:3 programs	Yes or <b>No</b>
Closed Captions	Choose to display subtitles and alerts on your TV screen	On or <b>Off</b> , and Configure Captions
Front Panel Settings	Set the brightness level of the front-panel lights (but not the <b>POWER</b> light)	Standby Brightness: Low, <b>Std.</b> , or High Viewing Brightness: Low, <b>Std.</b> , or <b>High</b>
HDMI Settings	Choose an Audio Output Mode, and to enable or disable automatic detection of a newly connected HDTV (when using an HDMI cable)	Audio Output Mode: <b>Auto</b> , L-PCM, or Pass Through Disable Auto Detect: Yes or <b>No</b>
Restore Defaults	Restore the user settings to their factory defaults	-

\*Factory default settings shown in **bold**.

## YOUR REMOTE CONTROL

Your RNG110 works with the Comcast Platinum remote control. For information on setting up and using your new remote control, read the operating instructions supplied with your remote control.



Manufactured under license from Dolby Laboratories. Dolby and the double-D symbol are trademarks of Dolby Laboratories.



HDMI, the HDMI Logo and High-Definition Multimedia Interface are trademarks or registered trademarks of HDMI Licensing LLC in the United States and other countries.

This product incorporates copyright protection technology that is protected by U.S. patents and other intellectual property rights. Use of this copyright protection technology must be authorized by Rovi Corporation, and is intended for home and other limited viewing uses only unless otherwise authorized by Rovi Corporation. Reverse engineering or disassembly is prohibited.

#### Open Source Licenses

The software contained in this product may be covered by certain components consisting of free software or open source software. A list of these components and a copy of the relevant copyright notices and license term notices that are required by such licenses are available at this web page:

<http://www.pace.com/opensource/license>

Other trademarks listed herein are the property of their respective owners.

## TROUBLESHOOTING

Check	Suggested solution	Further checks, if there is still a problem
Is anything lighted on your set-top's front panel? <b>YES</b> ▼	<b>NO</b> ► Press the <b>POWER</b> button on your remote control to turn on your set-top.	Make sure that the power supply unit is properly plugged in. If there is a switch by the wall AC outlet, switch it ON. Check that the wall AC outlet is working.
Does your remote control operate your set-top? <b>YES</b> ▼	<b>NO</b> ► Check if the <b>POWER</b> light on the front panel is green. If it is not, press <b>POWER</b> on your remote control to turn on your set-top.	Check that nothing is blocking the path from your remote control to the front panel. Check that your remote control is working and is set to operate your set-top. If your remote control will still not operate your set-top, replace the batteries in your remote control.
Can you see a picture on your TV screen? <b>YES</b> ▼	<b>NO</b> ► Check that your TV and other equipment are plugged in and turned on.	Check that you have selected the appropriate A/V input on your TV. If you are using the HDMI connection, make sure it goes directly from your set-top to your TV. Try disconnecting and reconnecting the standard HDMI cable. Make sure the set-top's TV Display Capability settings are appropriate for your TV. Press the <b>HD/ZOOM</b> button until a picture appears.
Is the picture distorted or too small? <b>NO</b> ▼	<b>YES</b> ► Check that the TV Aspect Ratio and TV Display Capability, as set on your set-top, are appropriate for your TV.	If your TV is a 16:9 TV, you can use Auto Pillarbox to add black borders to 4:3 transmissions, so that the picture is not stretched. If the set-top's settings are correct, try adjusting your TV's display.
Can you display menus and guides on the screen? <b>NO</b> ►	If your TV is connected to the VIDEO OUT connector, you will see menus and guides only if the resolution <b>480i</b> is set to <b>"Yes"</b> and all others are set to <b>"No"</b> .	Change the TV Display Capability resolution settings if necessary.

This guide describes some on-screen displays such as menus. These may change in the future. Please check <http://comcast.com> for the latest version of the Operator's Manual.

### HDTV with optional home theater using a single video and audio connection

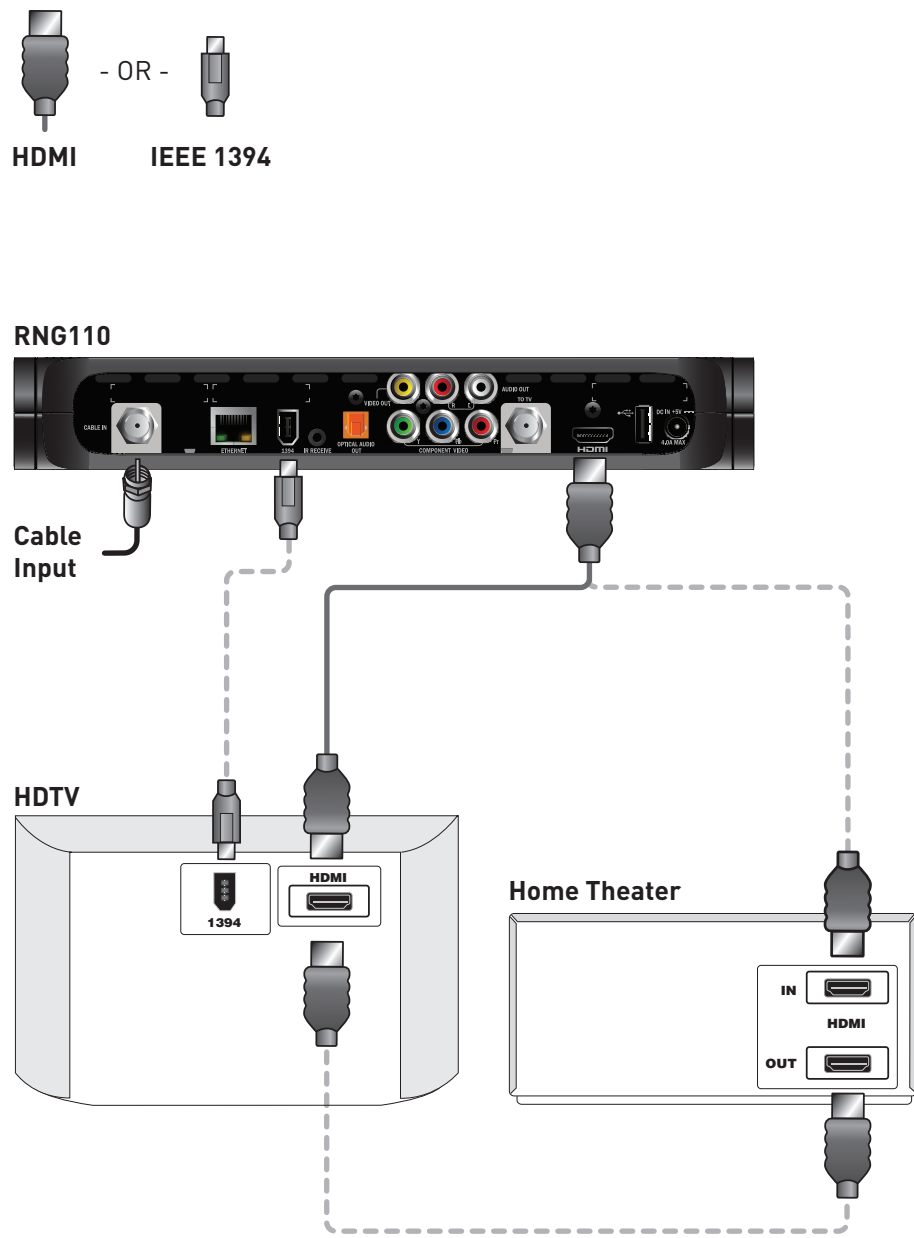

### HDTV and home theater using component video and digital audio connections

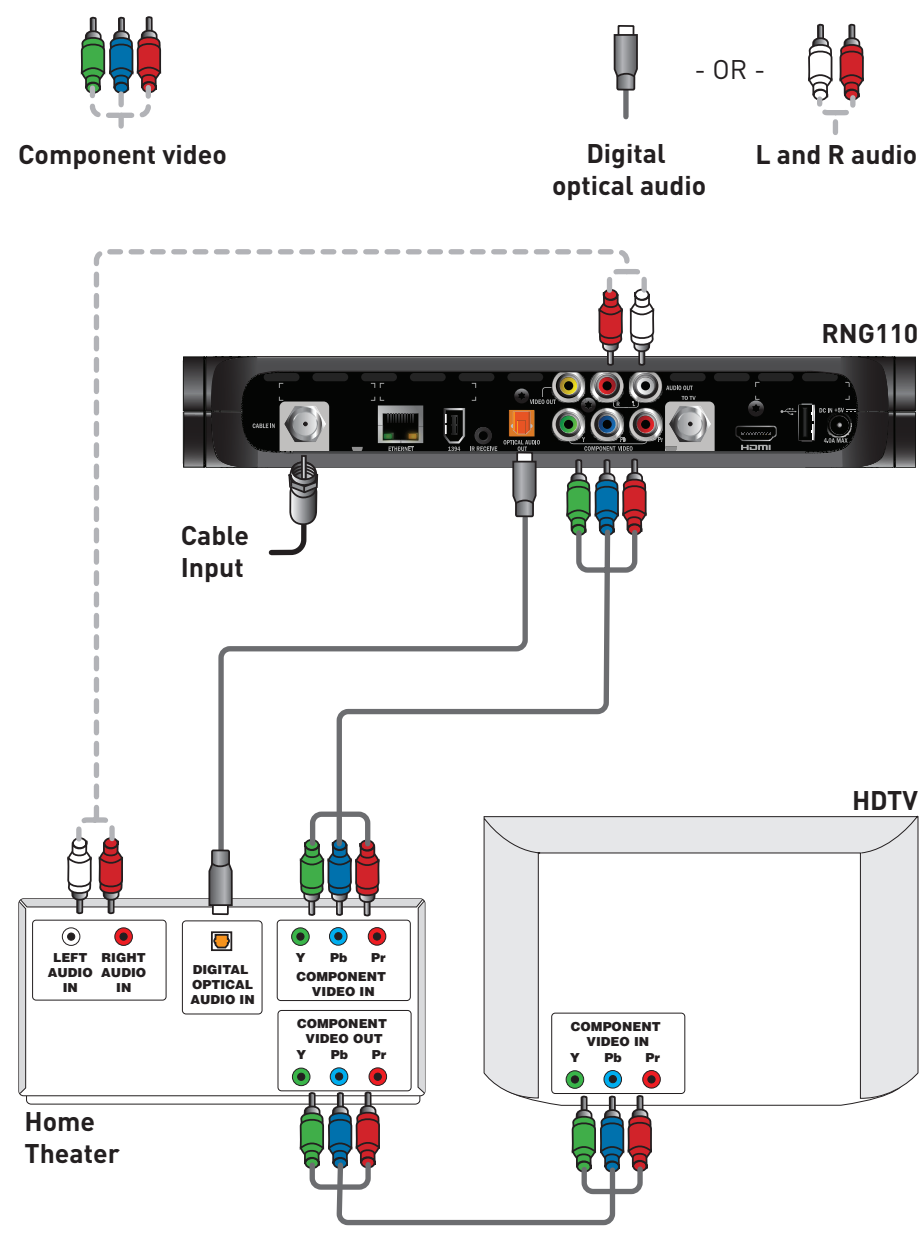

### SDTV only using composite video and audio connections

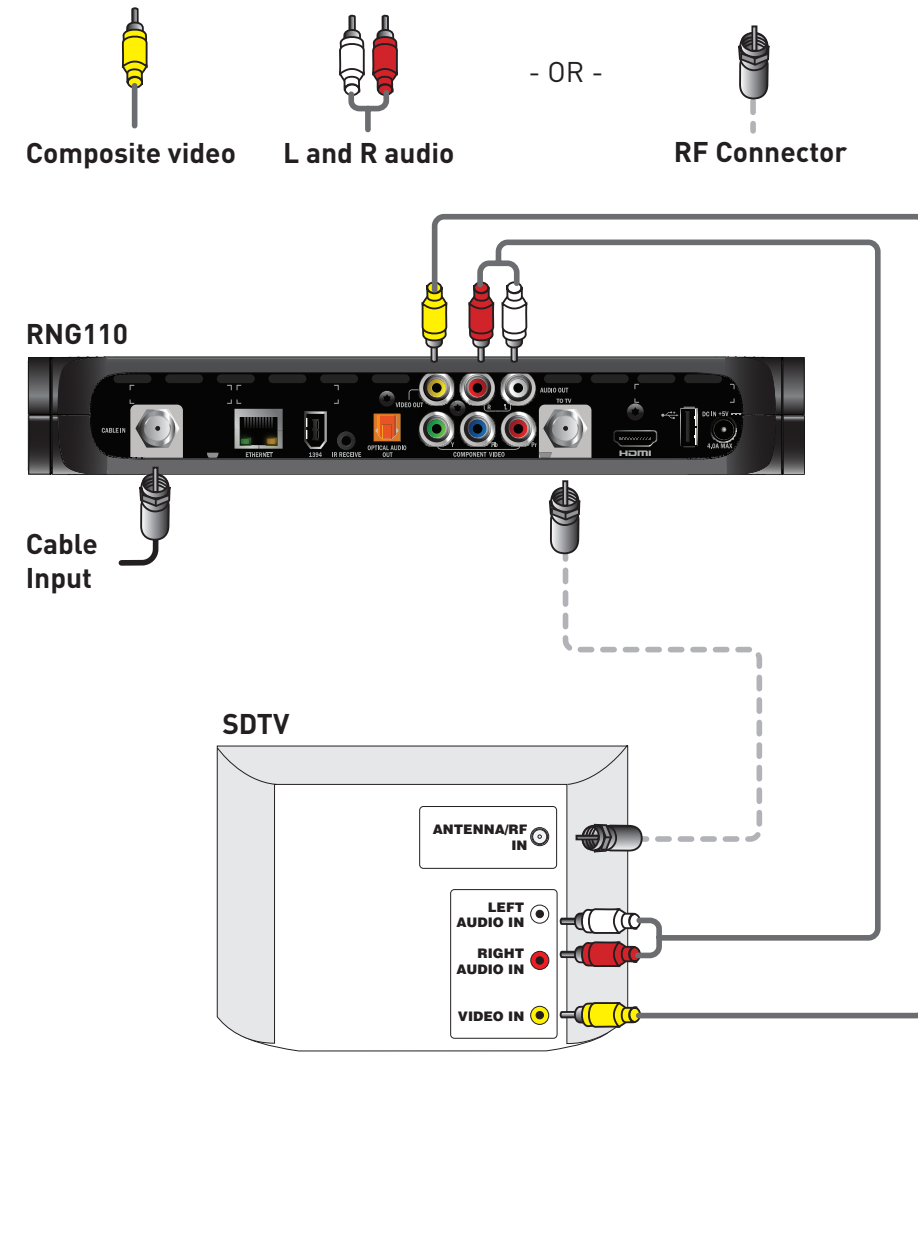

### SDTV and VCR/DVD recorder using composite video and audio connections

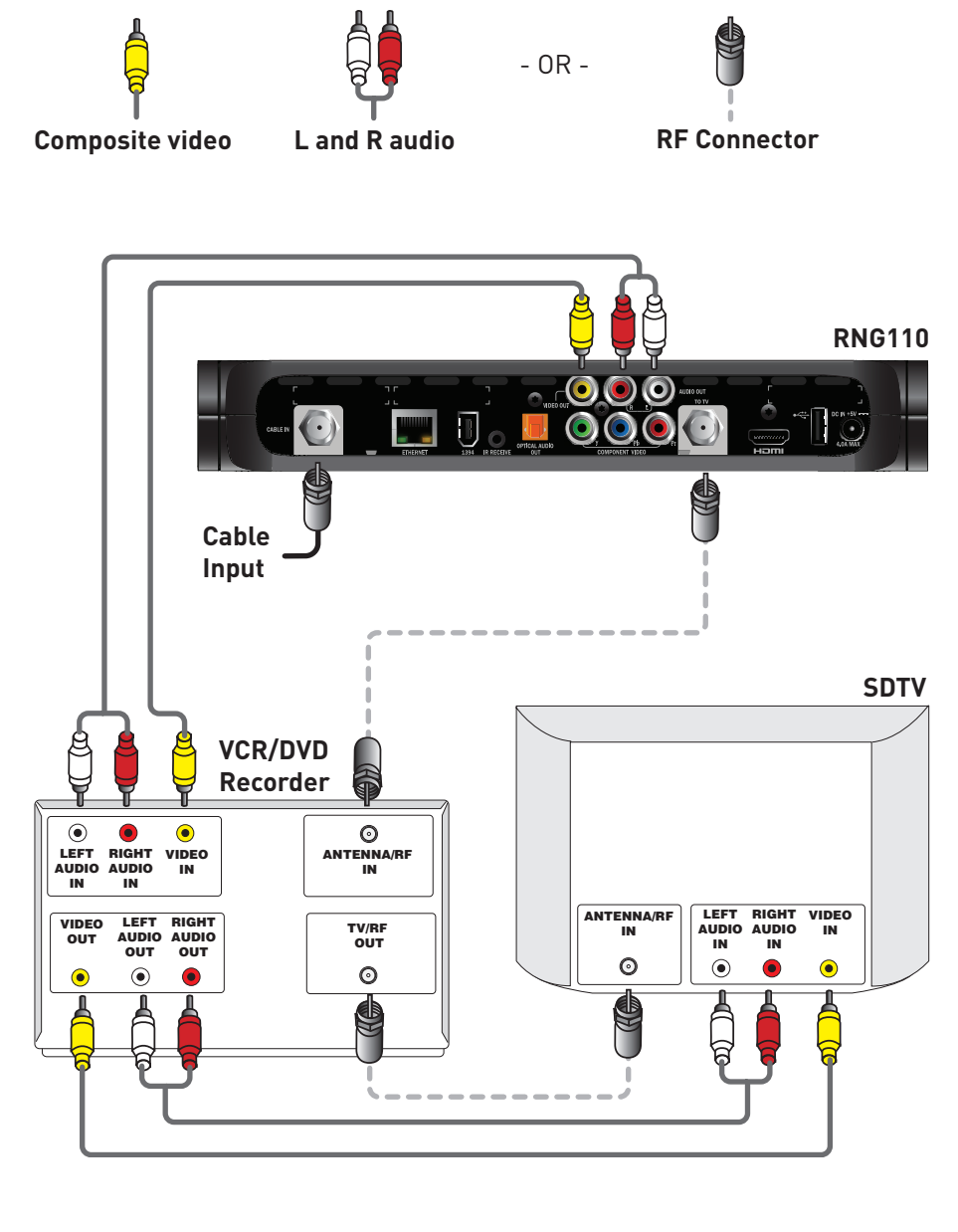

### HDTV only using separate video and audio connections

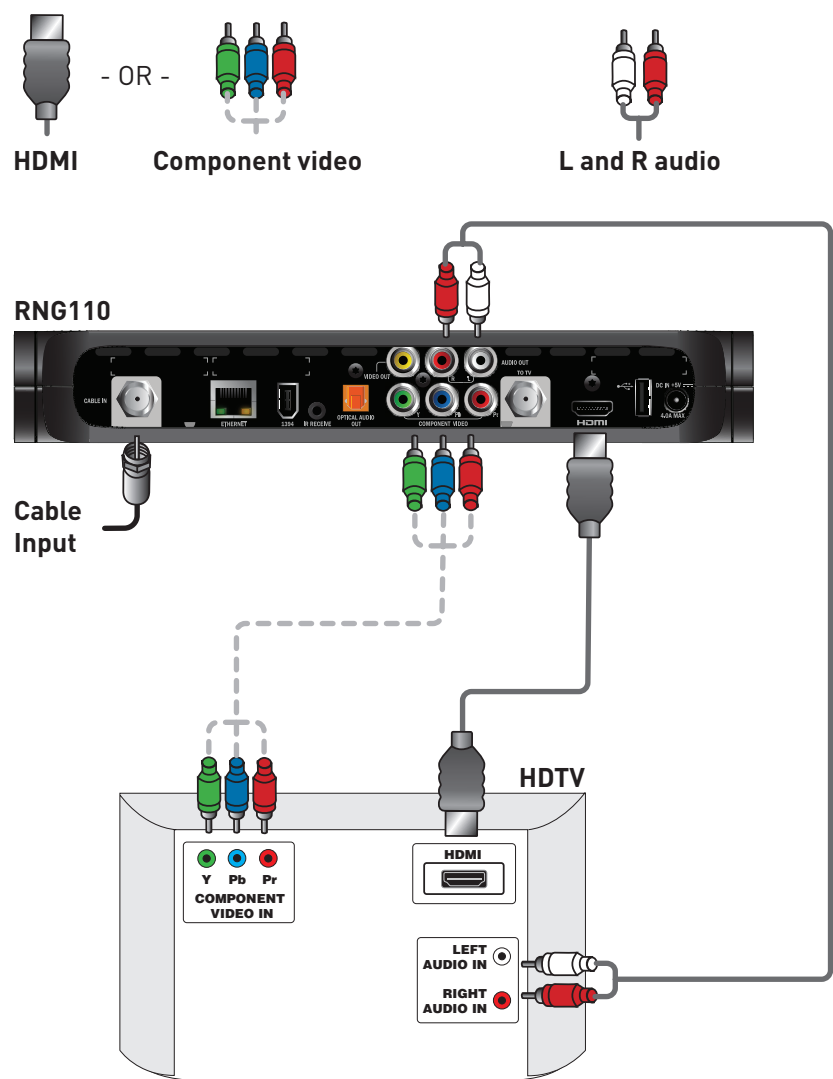

### RNG110 High-definition digital set-top



### SDTV, VCR/DVD recorder, and home theater using composite video and audio connections

